

SCORE[®] Revision

Revision Total Knee Arthroplasty
Cemented

Surgical
Technique
With Conventional
Instrumentation
Primary cases



TABLE OF CONTENTS

INTRODUCTION.....	3
SCORE® REVISION OVERVIEW.....	4
COMPONENTS COMPATIBILITY	8
PLANNING	9
INTRAMEDULLARY TIBIAL AIMING	10
TIBIAL CUT.....	11
CHECKING THE FLEXION AND EXTENSION GAPS	12
FEMORAL AIMING	13
FEMORAL CUTS	17
CHECKING THE FLEXION AND EXTENSION GAPS.....	18
FEMORAL NOTCH PREPARATION	18
ASSEMBLY OF TRIAL FEMORAL COMPONENT	20
POSITIONING OF TRIAL TIBIAL BASEPLATE	21
PREPARATION OF TIBIAL FOOTPRINT.....	22
PREPARATION OF TRIAL TIBIAL BASEPLATE	22
INSERTION OF TRIAL IMPLANTS.....	23
PATELLAR PREPARATION.....	24
INSERTION OF CHOSEN IMPLANTS	25
REPEATING THE DISTAL FEMORAL CUT	27
CHANGING SIZES	27
OPTIONAL: DISTAL FEMORAL PRECUT.....	28
OPTIONAL: SIMULATED GAP BALANCING BEFORE FEMORAL CUTS	29
INSTRUMENTATION	30

INTRODUCTION

- The SCORE® Revision is a revision total knee arthroplasty (TKA) system that can be used in primary cases.
- Frontal and sagittal joint stability are ensured by: – Complete congruency from 0° to 65° flexion – Intercondylar cam and cage mechanism.
- The SCORE® Revision is available as a cemented implant.

FEMORAL COMPONENT

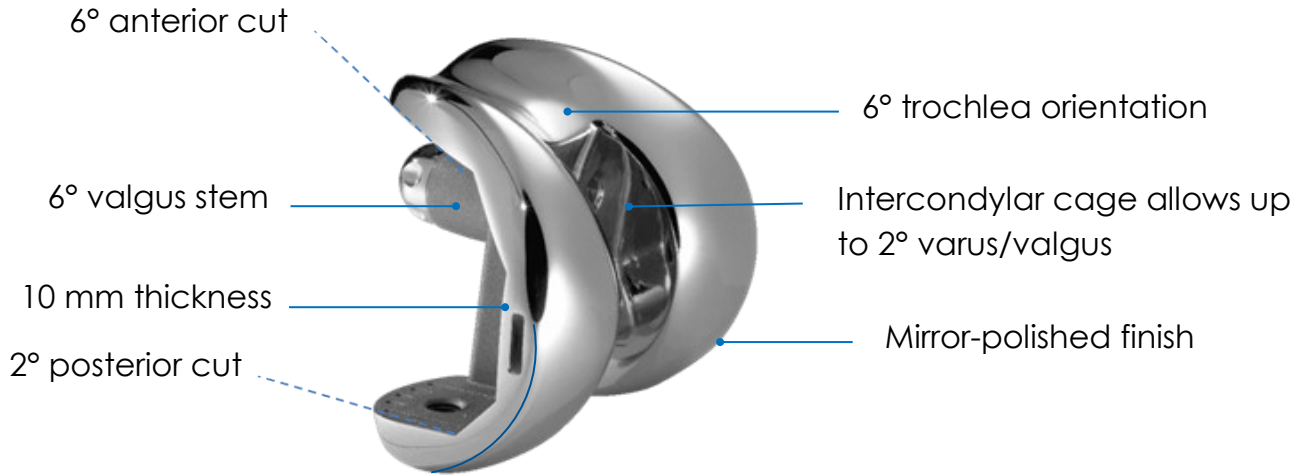

Single radius of curvature from 0° up to 90° flexion

Compatible extension stems:
Ø12 to 20 mm
Lengths 75 to 200 mm

Intercondylar cage is proportionally scaled in the frontal and sagittal planes

✓ Bone stock preserved

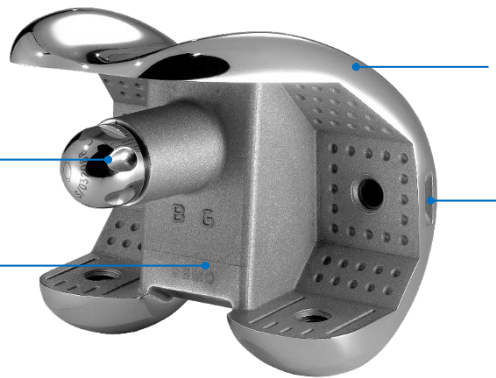

Made of Cobalt-Chrome

Notches on each side for holding the implant

Extension stems and distal augments:



PATELLAR COMPONENT

Resurfacing patellar implant - cemented

Thickness: 8 mm

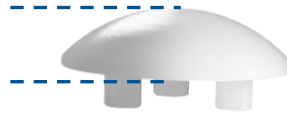

TIBIAL COMPONENTS

MOBILE TIBIAL INSERT:

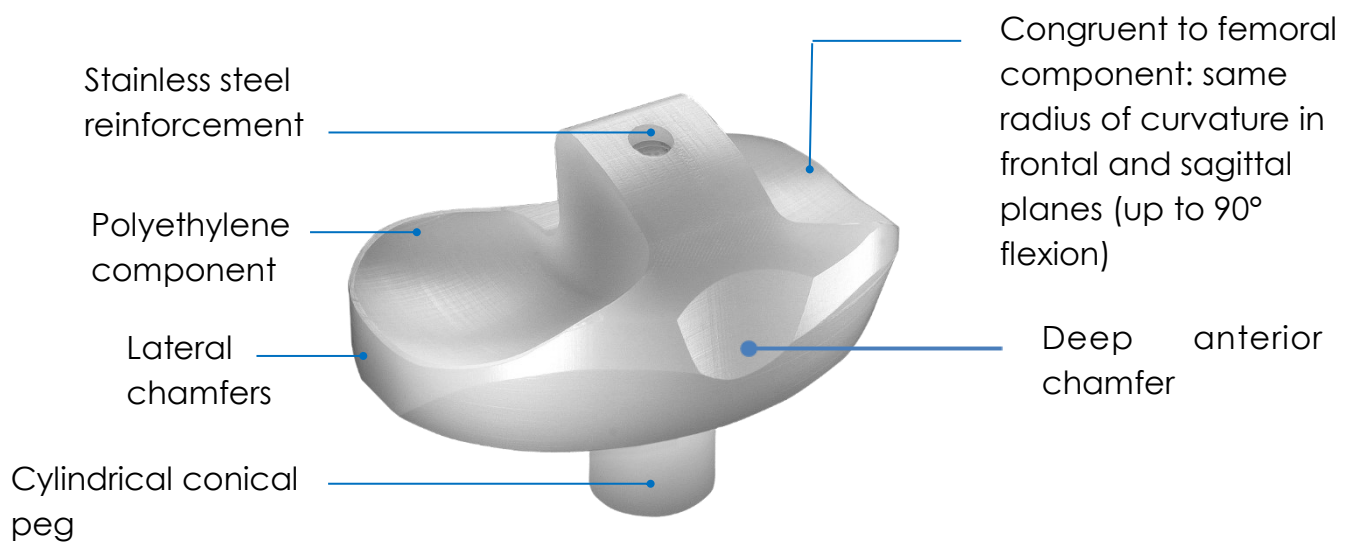

TIBIAL COMPONENTS

TIBIAL BASEPLATE:

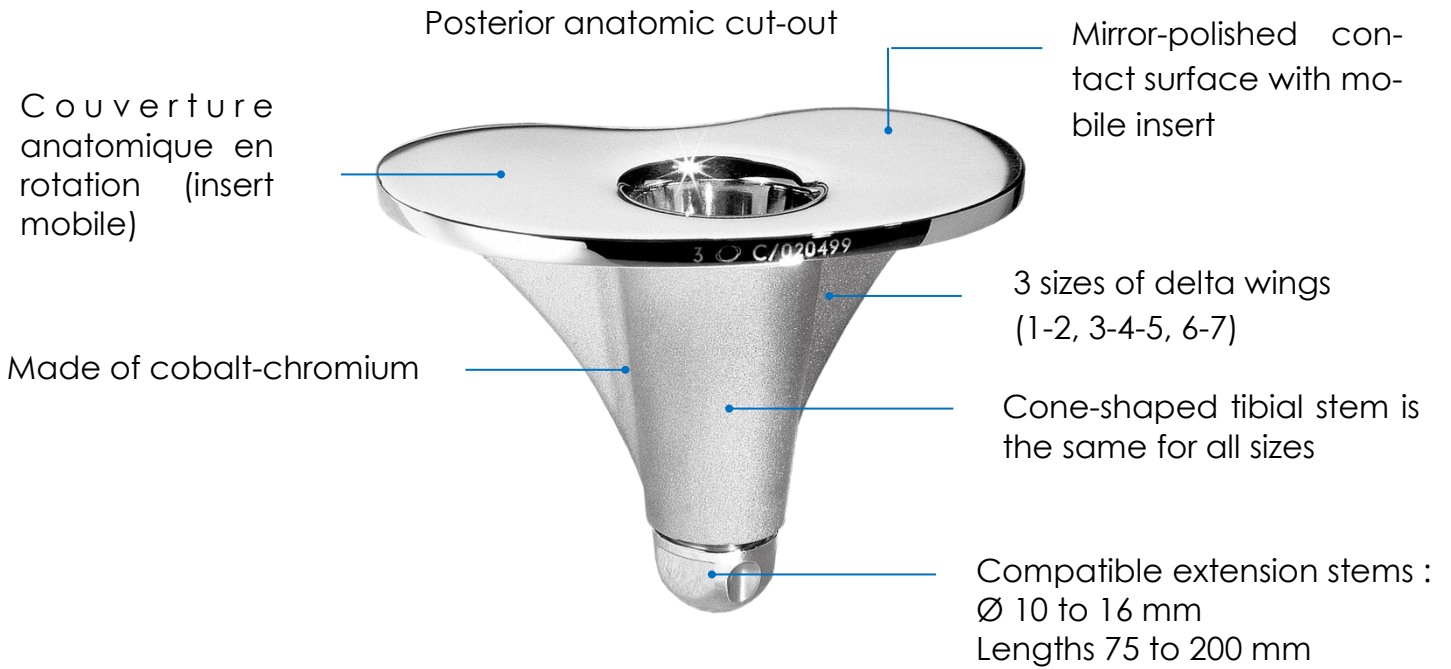

Extension stems, tibial augments and offset adapters:



RANGE

- **Femoral components:**
 - Cemented: 4 sizes

AP difference between sizes: 5 mm

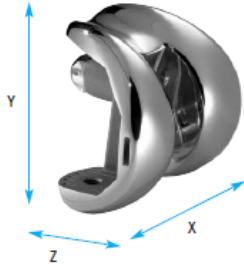

	A	B	C	D
ML (X) (mm)	61,6	67,2	72,8	78,4
AP (Y) (mm)	54,8	59,8	64,8	69,8
(Z) (mm)	50,6	55,2	59,8	64,4

- Extension stems:
 - Ø 12 to 20 mm
 - Lengths 75 to 200 mm



- Distal femoral augments: 4 or 8 mm thickness



- **Patellar components:**
 - Resurfacing patellar implant - cemented: Ø 30, 33 and 36 mm

- **Composants Tibial components:**
 - Cemented tibial baseplates: 7 sizes

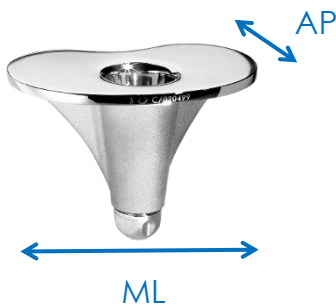

ΔAP: 2.3 mm

ΔML: 3.5 mm

	1	2	3	4	5	6	7
AP (mm)	41,4	43,6	45,9	48,2	50,5	52,8	55
ML (mm)	63,5	67	70,5	74	77,5	81	84,5

- Extension stems:
 - Ø 10 to 16 mm
 - Lengths 75 to 200 mm



- Tibial augments: 5, 10 or 15 mm thickness



- Offset adapters: 2, 4 or 6 mm



- Inserts: 4 sizes
 - 5 thicknesses: 10, 12, 14, 16 and 20 mm



COMPONENTS COMPATIBILITY

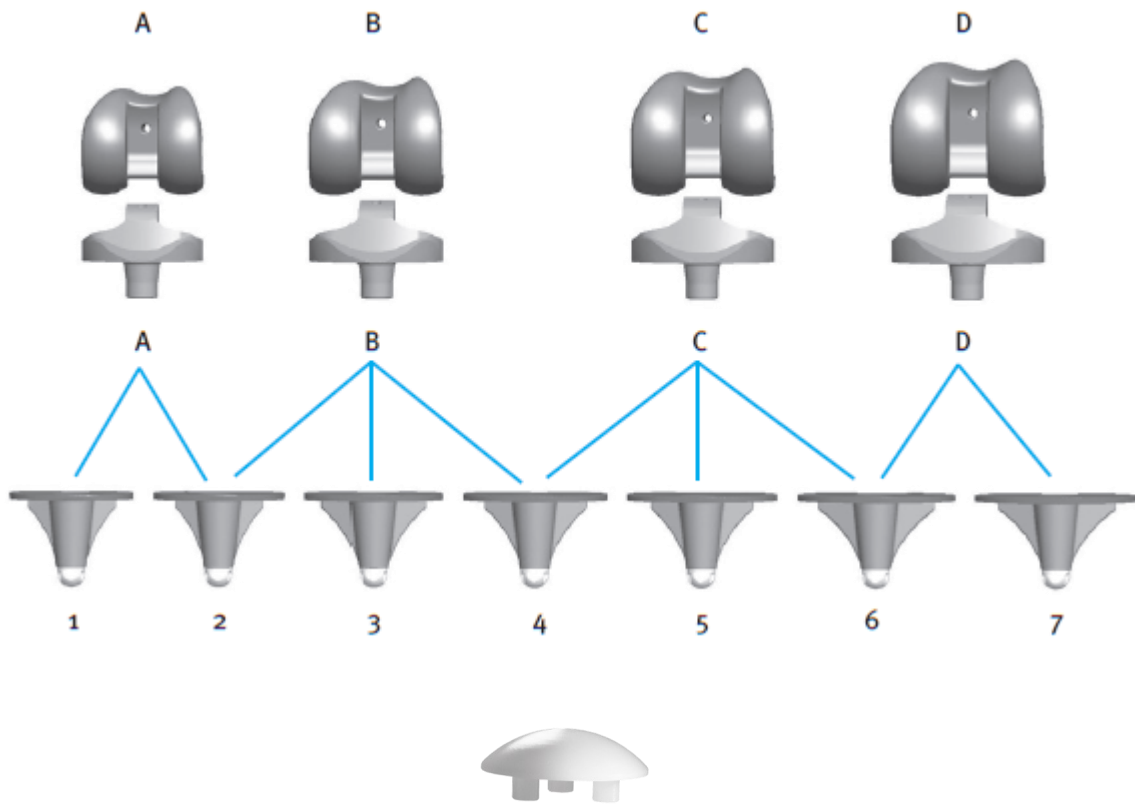

All sizes of cemented resurfacing patellar implants are compatible with all sizes of SCORE® REVISION femoral components.

TIBIAL AND FEMORAL EXTENSION STEMS

Length	Diameter					
	10	12	14	16	18	20
75	10	12	14			
100	10	12	14	16	18	20
150	10	12	14	16	18	20
200		12	14	16	18	20
	Tibia	Tibia and Femur			Femur	

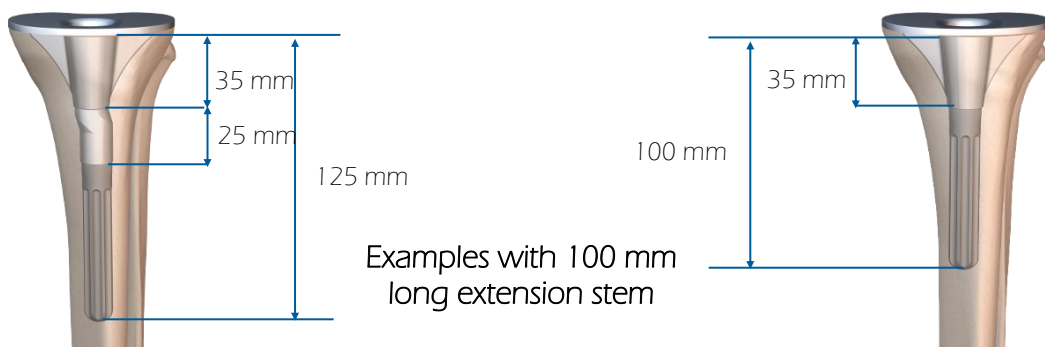

PLANNING

Radiographs and templates are used to determine the following:

On the tibia:

- Choice between intra- or extramedullary alignment method
- Lateral and A/P entry point for the intramedullary alignment guide
- Match between the tibial stem and metaphysis (e.g. following osteotomy)
- Presence of osteophytes
- Magnitude of wear in compartment
- Potential need for a tibial extension stem
- Estimated tibial baseplate size and insert thickness

On the femur:

- Lateral and A/P entry point for the intramedullary alignment guide
- Degree of native femoral valgus
- Presence of posterior osteophytes
- Femoral component size

On the patella:

- Wear in the patellofemoral joint
- Thickness, overall shape, tilt and height of patella
- Level and orientation of patellar bone cut
- ML position of patellar implant

NOTA

The provided templates have a 1:1 scale; other scaling options are available upon request.

REMINDER

The purpose of this surgical technique description is to provide instructions on how to use the instrumentation properly. The surgeon is fully responsible for choosing and performing the approach and surgical technique.

INTRAMEDULLARY TIBIAL AIMING



Locating the medullary canal:

- Hyperflex the knee and dislocate the tibia forward.
- Based on the preoperative plan, make a hole in the middle of the medullary canal using the Intramedullary drill bit.
- Place the Intramedullary rod length 400 mm on the T wrench and insert it into the canal; the landmark must always be visible.

NOTE

If the Intramedullary rod length 400 mm cannot be inserted, use the Intramedullary rod length 250 mm instead.

NOTE

If a tibial extension stem will be used, the next step is to gradually bore out the medullary canal using Reamers assembled with the T wrench.

Positioning the tibial instrumentation:

- Attach the Tibial slide bar and Tibial resection guide (left or right) together onto the Tibial bracket.
- Place these components on the Intramedullary rod.
- Before impacting the pegs, set the rotation of the Tibial bracket on the tibia.
- Set the resection height with the Tibial stylus as follows:
 - healthy side (10 mm cut relative to this reference)
 - worn side (same level as exit of saw blade)
 - for other resection heights, use the 2 mm markings on the Tibial slide bar.
- Check the level of the bone cut using the Resection gauge. This gauge can be used throughout the procedure on different cuts.



NOTE

If a tibial augment will be required, use the Revision Tibial Resection Guide (which is not compatible with navigation).

TIBIAL CUT

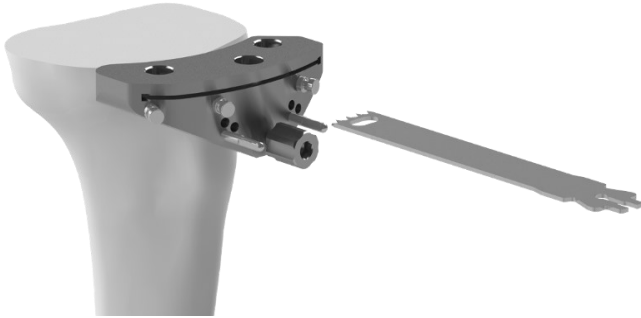

Tibial cut:

- Use a motorised handpiece and the Universal quick release adaptor for pin or Pin Driver AO to drive 2 Headless pins length 80 mm into the 0 landmarks on the Tibial Resection Guide.
- Use the Slap hammer to remove the intramedullary (and extramedullary) alignment rod.
- Set the Tibial Resection Guide against the bone.
- Stabilize the Tibial Resection Guide with 3 Headed pins length 70 mm; the pin holes can be predrilled with the Long Drill bit Ø3.2 length 145 mm.
- Perform the tibial cut(s) medial and lateral.
- Remove the Headed pins length 70 mm with the Pin extractor.
- Slide the Tibial Resection Guide off the Headless pins length 80 mm, but make sure the Headless pins length 80 mm stay in place in case recutting is required; if so, the +2 and +4 marks will be used.

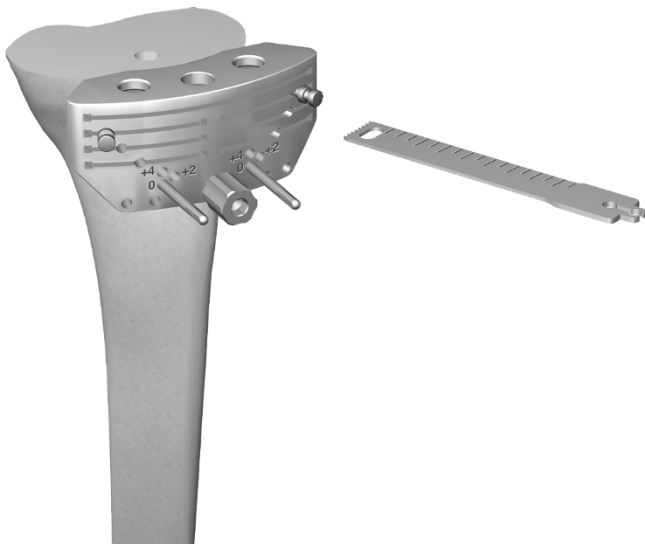

NOTE

Use a medium AMPLITUDE saw blade to make the tibial cuts and those of the tibial augments (slots at 5/10/15 mm) if needed.

NOTE

For the revision tibial resection guide, the Headed pins length 70 mm must be placed as close as possible to the main resection slot. In case of a resection for a tibial augment, choose the holes just below

CHECKING THE FLEXION AND EXTENSION GAPS

- Verify the gaps with a Spacer thickness 10 mm mounted on the Universal handle; the Extramedullary alignment rods can be assembled with this handle.
- The Spacers thickness 2, 4, 6 or 10 mm for spacer can be added to the Spacer thickness 10 mm to further refine ligament tension.

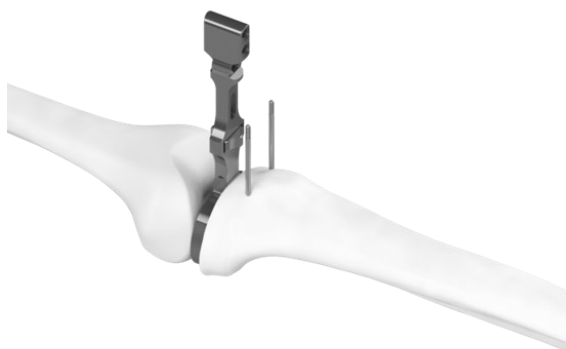

FEMORAL AIMING

Intramedullary femoral aiming:

- Flex knee 90°.
- Remove any peripheral osteophytes.
- Clear out tissues to access the anterior cortex.
- Based on the preoperative planning, locate the entry point on the femoral medullary canal, and drill a hole into it using a step Intramedullary drill bit.
- Place the Intramedullary rod length 400 mm on the T wrench and insert it into the canal; the landmark must always be visible.

NOTE

If the Intramedullary rod length 400 mm cannot be inserted, use the Intramedullary rod length 250 mm instead.

NOTE

If a tibial extension stem will be used, the next step is to gradually bore out the medullary canal using Reamers assembled with the T wrench.

FEMORAL AIMING

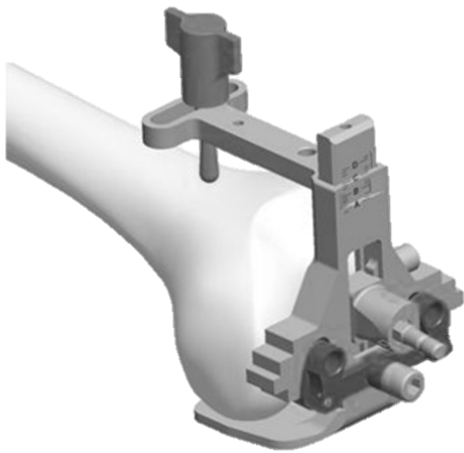

Femoral A/P measurement:

- Position the Revision Sizing guide with the Valgus Alignment Guide 6° and the Posterior Plate for Revision Sizing Guide.
- Ensure it touches at least one of the distal condyles.
- Make sure the Posterior Plate for Revision Sizing Guide rests on the two posterior condyles.
- Place the Anterior femoral stylus on the anterior cortex, moving it side to side as needed to select the desired reference point.
- Lock the AP adjustment by screwing the lateral screw with the H5 Screwdriver.
- Place the Spacer thickness 7 mm between the Plate for Revision Sizing Guide (3 mm thick) and the tibial cut to simulate a 10 mm thick tibial cut.
- The Spacers thickness 2, 4, 6 or 10 mm for spacer may be added to the Spacer thickness 7 mm to further refine the ligament tension.
- Evaluate the laxity with the knee flexed.

NOTE

In patients with a non-reducible flexion deformity, a distal femoral precut can be made (see page 28)

FEMORAL AIMING

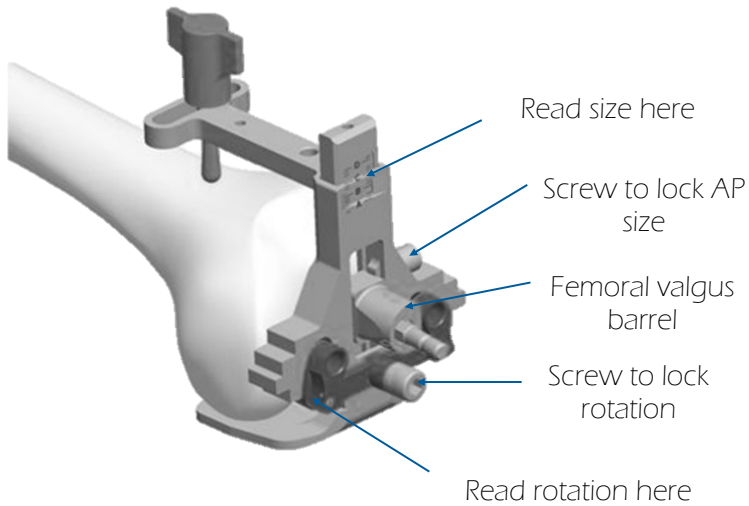

Femoral component size selection:

- Read the size from the markings.

There are two possible scenarios:

1: The reading corresponds to an exact size:

- The anterior and posterior reference points will be used simultaneously. The thickness of the bone cut will be equal to the thickness of the implant: 10 mm posteriorly.
- Fully tighten the side screw with the H5 Screwdriver

2: The reading is between two sizes:

- The next larger or smaller size can be used with either the anterior or posterior reference point.

Reading is between two sizes

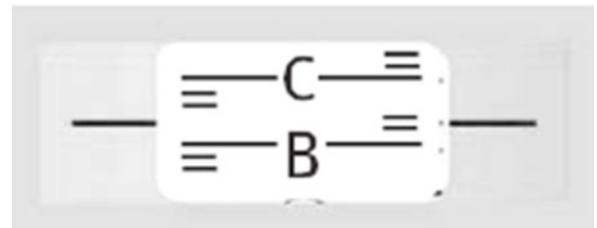

FEMORAL AIMING

Reading is between two sizes

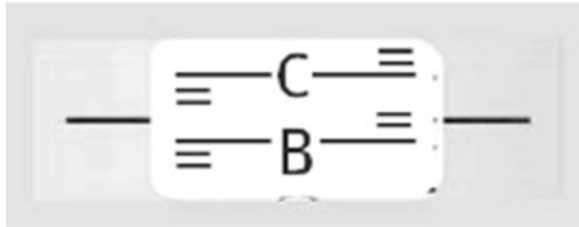

For an anterior reference point:

- The Posterior Plate for Revision Sizing Guide must rest against the posterior condyles.
- The Anterior femoral stylus must touch the anterior cortex.
- The measured gap (mm) is then factored into the posterior condyle cut.

For example, in the scenario on the previous page where the reading corresponds to **Size B + 2 mm or Size C - 3 mm:**

- **Smaller size selected** = 12 mm posterior cut (10 mm implant thickness)
Increased flexion gap.
- **Larger size selected** = 7 mm posterior cut (10 mm implant thickness)
Reduced flexion gap.

For a posterior reference point:

- Remove the Anterior femoral stylus but leave the Posterior Plate for Revision Sizing Guide against the posterior condyles.
- Place the laser marking at the chosen size.
- Fully tighten the side screw with the H5 Screwdriver.
- The measured gap (mm) is then factored into the anterior cut.

For example, in the scenario on the previous page where the reading corresponds to **Size B + 2 mm or Size C - 3 mm:**

- **Smaller size selected** = 10 mm posterior cut (10 mm implant thickness)
Anterior cut will be 2 mm lower due to the 6° anterior cut.
Flexion gap maintained; loads on patella reduced.
- **Larger size selected** = 10 mm posterior cut (10 mm implant thickness)
Anterior cut will be 3 mm higher.
Flexion gap maintained; loads on patella increased.

FEMORAL AIMING

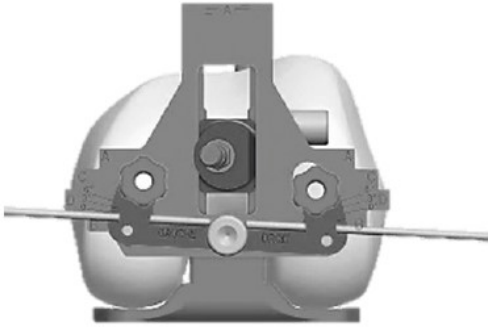

Setting the femoral rotation:

- The rotation can be determined using various anatomical and/or ligament-based landmarks.
- Anatomical landmarks:
 - Transepicondylar axis,
 - Posterior condylar axis,
 - Anteroposterior axis (Whiteside's line).
- Ligament-based landmarks:
 - An optional gap balancing simulator is available upon request (see page 29)
- Once the rotation has been determined, place the Drill guide for pin Ø 4 in the Revision Sizing guide with reference to the values indicated (0°, 3° or 6°) according to the operated side
- Fully tighten front screw with the H5 Screwdriver.

FEMORAL CUTS

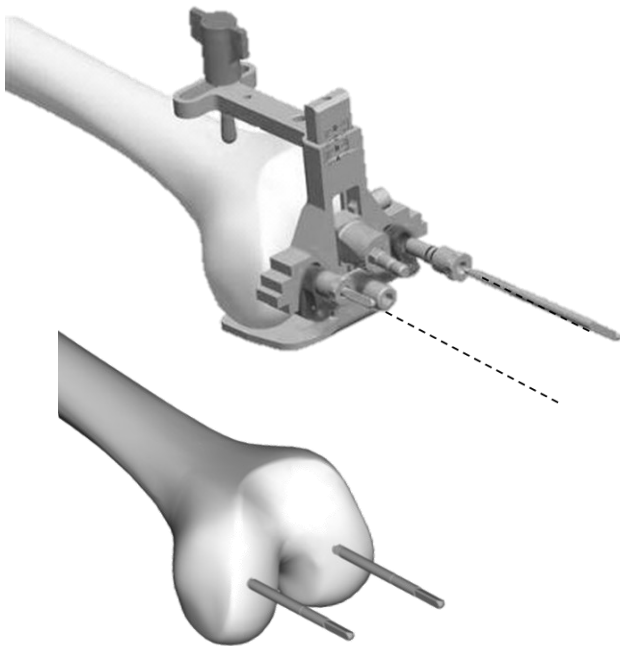

Pins insertion:

- Use a motorised handpiece to drive two Threaded pins Ø4 length 90 mm into the Drill guide for pin Ø 4 placed on the Revision Sizing guide until the landmark is reached.
- Use the Universal quick release adaptor for pin or Pin Driver AO to connect the Threaded pins Ø4 length 90 mm to the motorised handpiece.
- Remove the two Drill guide for pin Ø 4, the Intramedullary rod, and the Revision Sizing guide.

NOTE

The Universal quick release adaptor for pin can also be used with the T wrench.

Positioning of 5-in-1 resection guide and cuts:

- With the H5 Screwdriver, secure the Femoral resection guide stabilizer and at least one of the bracket for 5 in 1 Revision Femoral resection guide onto the 5-in-1 Revision femoral resection guide of the selected size.
- Place the 5-in-1 Revision femoral resection guide on the Threaded pins Ø4 length 90 mm.
- Make sure the 5-in-1 Revision femoral resection guide touches at least one of the distal condyles.
- To secure the construct, put two Headed pins length 50 mm into the bracket for 5 in 1 Revision Femoral resection guide and one Headless pin length 80 mm (unicortical) into Femoral resection guide stabilizer. A pin can be used in the notch instead of the Femoral resection guide stabilizer.
- Make the five cuts:
 - Anterior
 - Posterior
 - Anterior chamfer
 - Posterior chamfer
 - Distal
- Remove the Headed pins length 50 mm using the Pin extractor, and then remove the 5-in-1 Revision femoral resection guide.

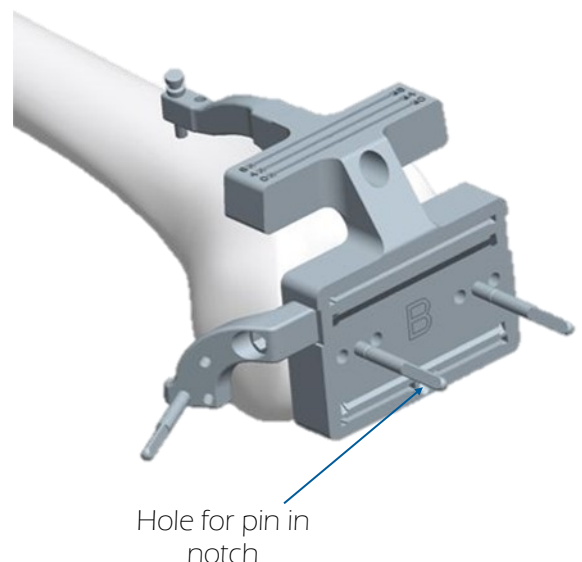

NOTE

Distal half-cuts of 4 or 8 mm can be made directly on the 5-in-1 Revision femoral resection guide.

CHECKING THE FLEXION AND EXTENSION GAPS



Checking the gaps:

- Verify the flexion and extension gaps with the Spacer thickness 20 mm (10 mm for the tibial cut plus 10 mm for the femoral component).
- The Spacer thickness 2, 4, 6 or 10 mm for spacer can be added to the Spacer thickness 20 mm, along with the femoral augment when distal femoral half-cuts have been made.

NOTE

To repeat the distal cut or change the size see page 27.

FEMORAL NOTCH PREPARATION

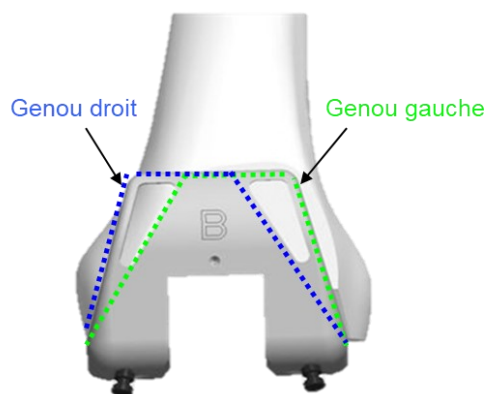

Positioning of Resection guide for the inter-condylar notch preparation:

- Set the Resection guide for the inter-condylar notch preparation on the femur; if needed, clip the Distal trial femoral wedge on the guide.
- The Resection guide for the inter-condylar notch preparation has the same mediolateral dimensions as the femoral component that will be implanted. Use the two windows on the anterior face of the guide to help position it: the outer (lateral) side of the guide corresponds to the outer edge of the replacement condyle and the inner (medial) side of the window corresponds to the inner edge of the replacement condyle.
- Secure the guide with two Headed pin length 30 mm or 50 mm.

FEMORAL NOTCH PREPARATION



Femoral reaming:

- Gradually ream the medullary canal using Reamers mounted on the T wrench.
- The graduated Reamers are used to estimate the most appropriate extension stem length.
- Use progressively larger Reamers (Ø10/12/14/16/18/20 mm) until contact is made with the bone cortex and good stability is achieved.

NOTE

The smallest femoral extension stem is 12 mm in diameter.

Preparation of intercondylar notch:

- Use the Chisel blade mounted on the Chisel blade handle to delicately prepare the intercondylar notch while staying in contact with the Resection guide for the inter-condylar notch preparation.

NOTE

If the bone is very dense, a medium saw blade can be used to prepare the cut.



FEMORAL NOTCH PREPARATION

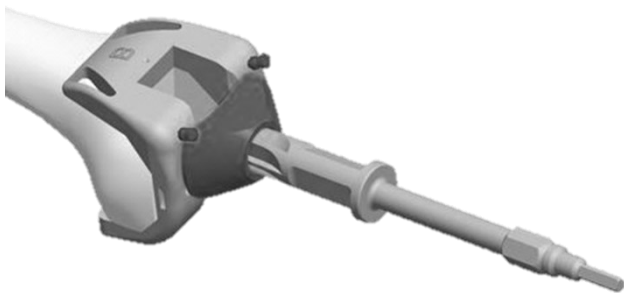

Entry point for extension stem:

- Set the Femoral Reamer Guide on the Resection guide for the inter-condylar notch preparation corresponding to the operated leg.
- Use a motorised handpiece to insert the Femoral reamer for the extension stem entry point until it stops (same for all sizes).
- Verify the depth and quality of the intercondylar notch preparation using the Inter-condylar box trial (on which the Removable handle for punch guide has been assembled). The Inter-condylar box trial must fit in the notch perfectly and be level with the distal femoral cut.
- Remove the Headed pins using the Pin extractor and remove the Resection guide for the inter-condylar notch preparation.

ASSEMBLY OF TRIAL FEMORAL COMPONENT

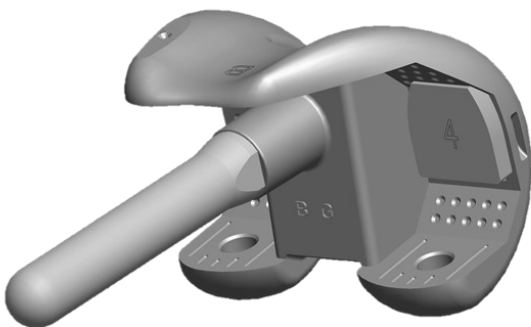

- Screw the Trial extension stem (same length and diameter as last Reamer used) to the SCORE Revision femoral component using the Stem Wrench with Universal Screwdriver H3.5.
- Set the Distal trial femoral wedge (4 or 8 mm) on the SCORE Revision femoral component if needed.

POSITIONING OF TRIAL TIBIAL BASEPLATE

NOTE

Remove the two Headless pin length 80 mm that were left in the tibia.



- Gradually ream the medullary canal using Reamers mounted on the T wrench.
- The graduated Reamers are used to estimate the most appropriate extension stem length.
- Use progressively larger Reamers (Ø10/12/14/16 mm) until contact is made with the bone cortex and good stability is achieved.
- Leave the last Reamer used in place.
- Select the Trial Tibial Baseplate that provides the best possible bone coverage (refer to chart on page 8 for femoral and tibial size compatibility).
- Assemble the Offset positioner for trial tibial baseplate - 0 mm with the Trial Tibial Baseplate.
- Place these two components onto the Reamer, against the previously-made tibial cut.
- If the Trial Tibial Baseplate does not fully cover the tibial cut surface when it is centred on the reamer, change to the Offset positioner for trial tibial baseplate - 2, 4 or 6 mm instead.
- Turn the Offset positioner for trial tibial baseplate until the Trial Tibial Baseplate covers the cut surface completely.
- Make a note of the offset adapter size and its position using the graduations on the Offset positioner for trial tibial baseplate and the mark on the trial baseplate. This information will be used during the assembly of the trial and final components.
- Secure the unit with two Headed pins; the appropriate pin length (30, 50 or 70 mm) depends on the thickness of any tibial augments that is used.
- Remove the Reamer and the Offset positioner for trial tibial baseplate.

PREPARATION OF TIBIAL FOOTPRINT

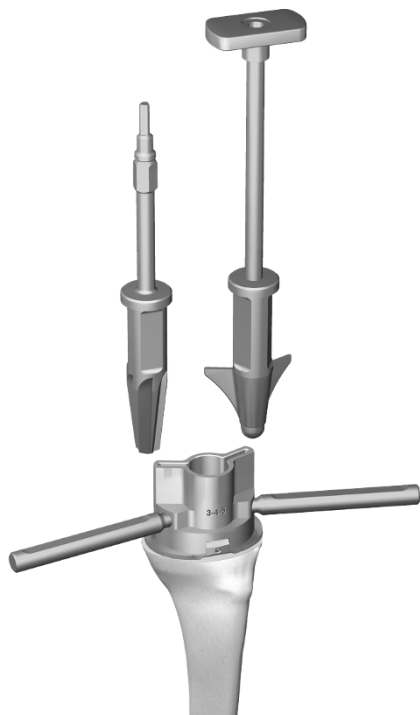

- Tighten the Standard Trial Stem on the Punch Guide for Tibial Baseplate with the Tibial Stem Wrench.
- Position the Punch guide for tibial baseplate of the size corresponding to the Trial Tibial Baseplate.
- Use a motorised handpiece to insert the Reamer for tibial extension stem until it stops (same for all sizes).
- Make the entry point for the delta wing using the Punch for tibial extension stem (use an osteotome if the bone is sclerotic or an osteotomy has been performed).

NOTE

Check the integrity of the 2 instruments (Punch and Trial Stem) after extraction of the assembly.

PREPARATION OF TRIAL TIBIAL BASEPLATE



- Screw the Trial extension stem (length and diameter correspond to final Reamer used) to the Trial offset connector corresponding to the selected Offset positioner for trial tibial baseplate. These components are assembled using the Wrench for Offset Connector and Stem Wrench with Universal Screwdriver H3.5.
- With the H5 Screwdriver, tightly screw this unit to the Delta wing for tibial trials while making sure the position of the Trial offset connector previously determined from the Trial Tibial Baseplate is maintained.
- Impact the Delta wing for tibial trials /Trial offset connector (if used)/Trial extension stem unit through the Trial Tibial Baseplate into the tibia until it stops.
- Secure the entire unit to the Trial Tibial Baseplate using the Thumb knob to connect baseplate / delta wing. Tests can now be carried out in the same configuration as the final implants.

NOTE

If no Trial offset connector is used, screw the Trial extension stem directly into the Delta wing for tibial trials.

INSERTION OF TRIAL IMPLANTS

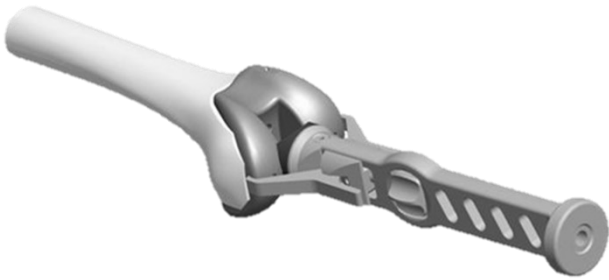

- Assemble the SCORE Revision femoral component with the Femoral condyle holder (trial position).
- Resect any posterior osteophytes with the osteotome.
- Insert the chosen SCORE Revision Trial Insert.
- Verify the joint's motion and stability during flexion and extension.



PATELLAR PREPARATION



Patellar preparation:

- Remove the osteophytes.
- Measure the thickness of the patella.

Positioning the Patellar Resection Clamp:

- Place the Patellar Resection Clamp so the two lugs are on the anterior side of the patella.
- With the clamp jaws open, bring the Patellar resection gauge into contact with the articular surface using the adjustment knob.
- Lock the clamp.
- Read how much bone remains.
- Make the cut.

End of patellar preparation:

- Use the Patellar Drilling Guide to determine the size of patellar implant needed: 30, 33 or 36 mm in diameter.
- Centre and impact the Patellar Drilling Guide.
- Make the pilot holes for the three pegs using the Drill Bit for Resurfacing Patella.
- Use the Clamp for Locking Ring to set the Trial resurfacing patella in place.
- Check the patellar tracking over the entire flexion/extension range.

Positioning the patellar implant:

- Make sure the patellar surface is clean and dry.
- Apply a layer of cement to the implant.
- Insert the chosen patellar implant.
- Remove any excess cement.
- Use the Patellar Impaction Clamp to hold the patellar implant while the cement sets.

NOTE

All resurfacing patellar implants are 8 mm thick. It is recommended to keep 12 mm of residual patella bone while respecting the anterior offset of the patient.



INSERTION OF CHOSEN IMPLANTS

Assembly of chosen tibial implants:

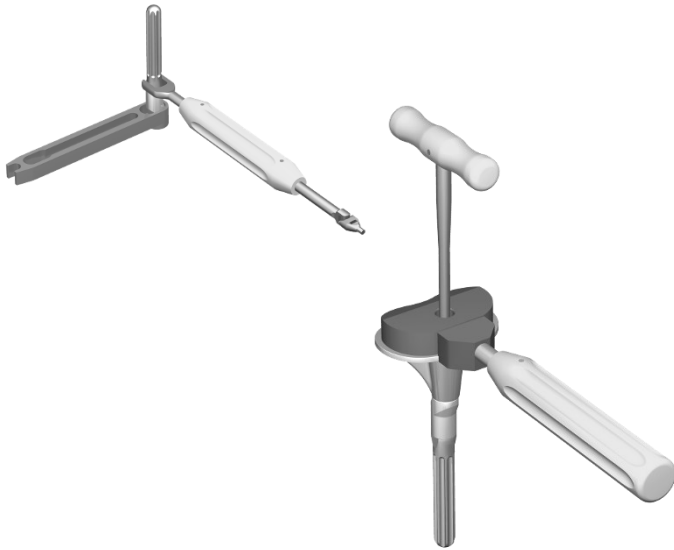

- Screw the tibial extension stem to the offset adapter that corresponds to the validated tibial offset positioner. These components are assembled using the Wrench for Offset Adapter and Stem Wrench with Universal Screwdriver H3.5. If no offset adapter is used, screw the extension stem directly into the tibial baseplate.
- Impact the whole unit into the tibial baseplate while matching the position determined during tibial preparation (laser markings can be found on the edge of the delta wing).
- Place the Tibial impactor with offset connector into the female side of the baseplate taper and lock to the anterior edge of the baseplate.
- Using the H5 Screwdriver, tighten the screw of the Tibial impactor with offset connector. As a result, the offset adapter is pulled into the cone of the tibial baseplate.

Insertion of chosen tibial implants:

- Carefully clean the implant site by washing .
- Prepare the bone cement and apply it to the tibial cut surface or under the tibial baseplate.
- If using a tibial augment, apply a thin layer of cement between the augment and tibial baseplate.
- Impact the final components into the tibia using the Baseplate impactor and make sure the augment is perfectly positioned relative to the tibial baseplate and tibial cut.
- Tighten the Tibial impactor with offset connector one last time before removing it completely.
- Remove any excess cement.
- Place a tibial insert of the size corresponding to the femur and thickness validated during the trials.

INSERTION OF CHOSEN IMPLANTS

Assembly of chosen femoral component:

- If necessary, screw the femoral augument (4 or 8 mm) using the Stem Wrench with Universal Screwdriver H3.5.
- Screw the femoral extension stem directly into the revision femoral component using the Stem Wrench with Universal Screwdriver H3.5.

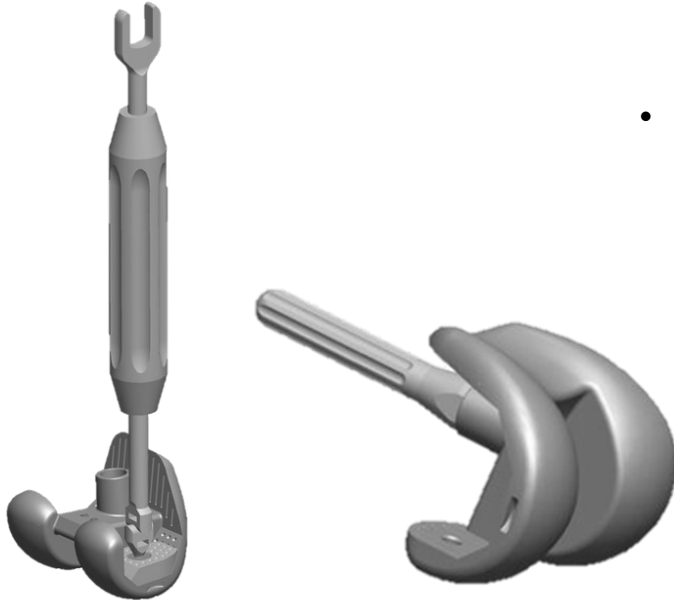

NOTE

If using a large femoral extension stem, make avec sure it does not contact the anterior cortex.

Insertion of chosen femoral component:

- Assemble the femoral component with the Femoral condyle holder.
- Carefully clean the implant site by washing .
- Prepare the cement and apply it to the femoral implant or bone surfaces.
- Do not put too much cement on the posterior side.
- Hyperflex the knee.
- Set the femoral component on the femur.
- Remove the Femoral condyle holder and then impact the implant using the Femoral component impactor.
- Carefully remove any excess cement.
- Fully extend the knee to maintain pressure while the cement sets.

REPEATING THE DISTAL FEMORAL CUT

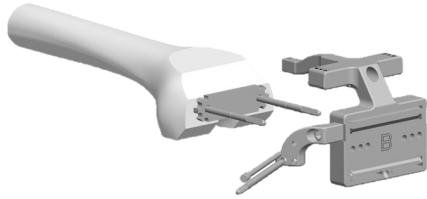

Size B guide

- Put the two Threaded pins Ø4 length 90 mm back into place.
- Position the appropriate Femoral recutting wedge on those pins.
 - 8 mm thick wedge: 2 mm recut
 - 6 mm thick wedge: 4 mm recut
 - 4 mm thick wedge: 6 mm recut
- Set the 5-in-1 Revision femoral resection guide that was initially used (with the Femoral resection guide stabilizer and at least one bracket for 5 in 1 Revision Femoral resection guide) against the Femoral recutting wedge.
- To secure the 5-in-1 Revision femoral resection guide, put two Headed pins length 50 mm into the bracket for 5 in 1 Revision Femoral resection guide and one Headless pin length 80 mm (unicortical) into Femoral resection guide stabilizer.
- Remove the two Threaded pins Ø4 length 90 mm and the Femoral recutting wedge.
- Make the cuts.

CHANGING SIZES

- Put the two Threaded pins Ø4 length 90 mm back back into place.
- Place the Femoral recutting wedge – 4 mm and 6 mm on these two Threaded pins Ø4 length 90 mm.
- Set the 5-in-1 Revision femoral resection guide of the next size down (with the Femoral resection guide stabilizer and at least one bracket for 5 in 1 Revision Femoral resection guide) against the Femoral recutting wedge.
- To secure the 5-in-1 Revision femoral resection guide, put two Headed pins length 70 mm into the bracket for 5 in 1 Revision Femoral resection guide and one Headless pin length 80 mm (unicortical) into Femoral resection guide stabilizer.
- Remove the two Threaded pins Ø4 length 90 mm and the Femoral recutting wedge.
- Make the cuts.

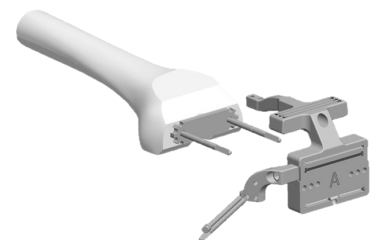

Size A guide

OPTIONAL: DISTAL FEMORAL PRECUT

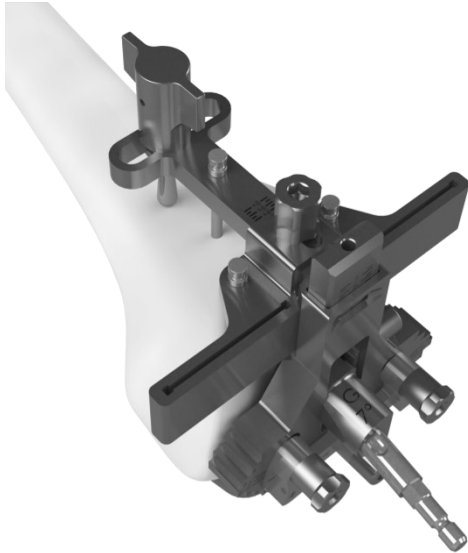

In patients with a significant preoperative flexion deformity, a 2 or 4 mm distal femoral precut can be made.

- Secure the Additional distal resection guide onto the front part of the Revision Sizing guide and transfer the chosen value.
- Insert two Headed pin length 30 mm or 50 mm.
- Once the cut has been made, put the Revision Sizing guide back into place so it touches the distal condyles.

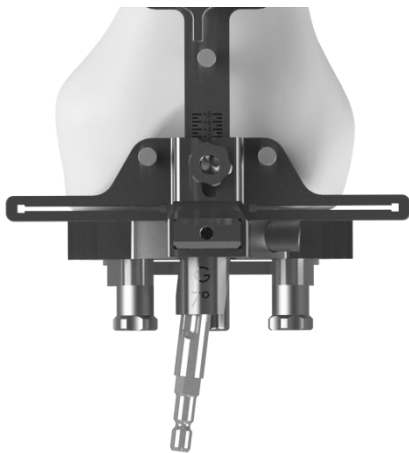

SCORE® REVISION — PRIMARY CASES

OPTIONAL: SIMULATED GAP BALANCING BEFORE FEMORAL CUTS

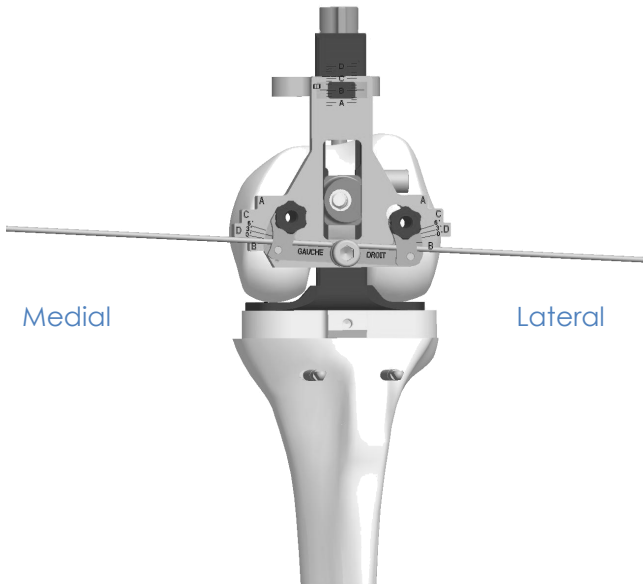

- Place the Revision Sizing guide and the valgus Valgus Alignment Guide 6° on the Intramedullary alignment rod.
- Simulate gap balancing with 0°, 3° or 6° external rotation by using the appropriate spacer.
- Once the rotation has been determined, fully tighten the front screw with the H5 Screwdriver.

NOTE

This gap balancing simulator is optional

INSTRUMENTATION

The SCORE® Revision primary instrumentation consists of 6 trays:

- SCORE® Revision — common basis instrumentation set:
 - ◆ Common Set
 - ◆ Stem and Augment Set
 - ◆ Femur and Tibia Trials Set
 - ◆ Patella and Impaction Set
- SCORE® revision for primary cases instrumentation set:
 - ◆ Tibial Preparation/Cutting Set
 - ◆ Femoral Preparation/Cutting Set

In addition:

- Sterile medium saw blades

INSTRUMENTATION

SCORE® REVISION - COMMON BASIS

2-02999125

COMMON SET

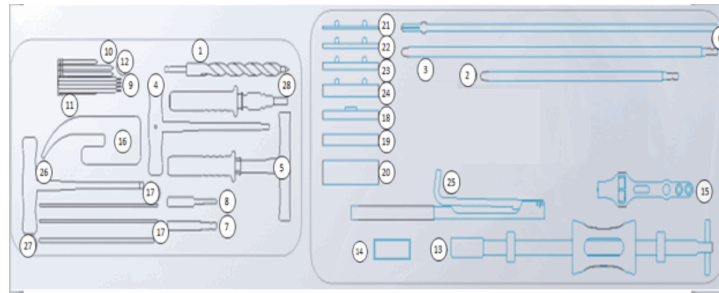

Item	Name	Product No.	Qty
1	Intramedullary drill bit	2-0200100	1
2	Intramedullary rod length 250 mm	2-0200200	1
3	Intramedullary rod length 400 mm	2-0200300	1
4	H5 Screwdriver	2-0200800	1
5	T wrench	2-0200400	1
6	Extramedullary alignment rod	2-0200600	2
7	Universal quick release adaptor for pin	2-0201100	1
8	Pin Driver AO	2-0201200	1
9	Headless pin length 80 mm	2-0201400	4
10	Headed pin length 30 mm	2-0201301	3
11	Headed pin length 50 mm	2-0201303	6
12	Headed pin length 70 mm	2-0201302	6
13	Slap hammer	2-0206900	1
14	Slap hammer tip	2-0214800	1
15	Universal handle	2-0216400	1
16	Resection gauge	2-0204500	1
17	Alignment Pin Ø 2 Length 150 mm	2-0103000	2
18	Spacer thickness 7 mm	2-0200707	1
19	Spacer thickness 10 mm	2-0200710	1
20	Spacer thickness 20 mm	2-0200720	1
21	Spacer thickness 2 mm for spacer	2-0207002	1
22	Spacer thickness 4 mm for spacer	2-0207004	1
23	Wedge thickness 6 mm for spacer	2-0207006	1
24	Wedge thickness 10 mm for spacer	2-0207010	1
25	Pin extractor	2-0201500	1
26	Extractor for offset connector	2-0214300	1
27	Long Drill bit Ø3.2 length 145 mm	2-0102400	1
28	Universal AO connector	2-0211700	1

INSTRUMENTATION

SCORE® REVISION - COMMON BASIS

2-02999125

STEM AND AUGMENT SET

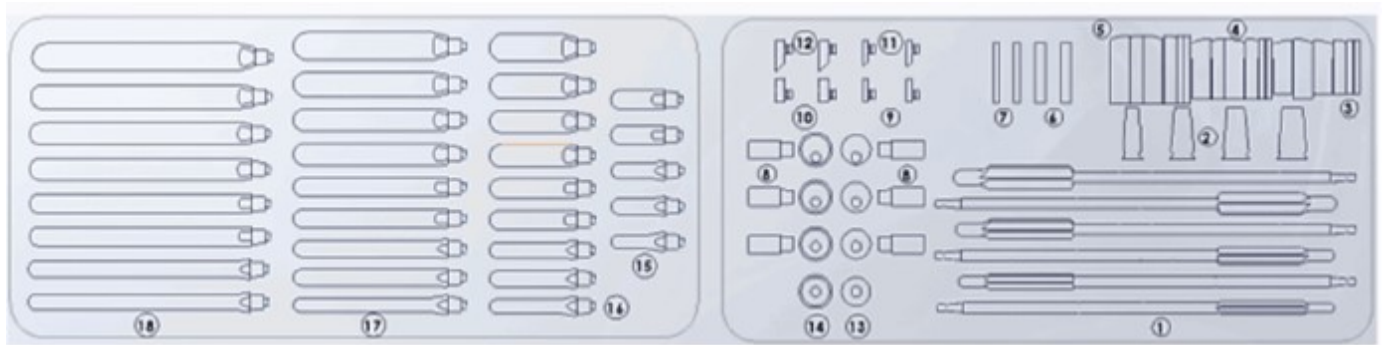

Item	Name	Product No.	Qty
1	Reamer Ø10	2-0210510	1
1	Reamer Ø12	2-0210512	1
1	Reamer Ø14	2-0210514	1
1	Reamer Ø16	2-0210516	1
1	Reamer Ø18	2-0210518	1
1	Reamer Ø20	2-0210520	1
2	Sleeve 10/15	2-0211400	1
2	Sleeve 12/19	2-0211401	1
2	Sleeve 14/21	2-0211402	1
2	Sleeve 16/23	2-0211403	1
3	Trial tibial half-wedge - Size 1/2 thickness 5 mm	2-0210311	2
3	Trial tibial half-wedge - Size 1/2 thickness 10 mm MED.R / LAT.L	2-0210321	1
3	Trial tibial half-wedge - Size 1/2 thickness 15 mm MED.R / LAT.L	2-0210331	1
3	Trial tibial half-wedge - Size 1/2 thickness 10 mm LAT.R./MED.L	2-0210341	1
3	Trial tibial half-wedge - Size 1/2 thickness 15 mm LAT.R./MED.L	2-0210351	1
4	Trial tibial half-wedge - Size 3/4/5 thickness 5 mm	2-0210313	2
4	Trial tibial half-wedge - Size 3/4/5 thickness 10 mm MED.R / LAT.L	2-0210323	1
4	Trial tibial half-wedge - Size 3/4/5 thickness 15 mm MED.R / LAT.L	2-0210333	1
4	Trial tibial half-wedge - Size 3/4/5 thickness 10 mm LAT.R./MED.L	2-0210343	1
4	Trial tibial half-wedge - Size 3/4/5 thickness 15 mm LAT.R./MED.L	2-0210353	1
5	Trial tibial half-wedge - Size 6/7 thickness 5 mm	2-0210316	2
5	Trial tibial half-wedge - Size 6/7 thickness 10 mm MED.R / LAT.L	2-0210326	1
5	Trial tibial half-wedge - Size 6/7 thickness 15 mm MED.R / LAT.L	2-0210336	1
5	Trial tibial half-wedge - Size 6/7 thickness 10 mm LAT.R./MED.L	2-0210346	1
5	Trial tibial half-wedge - Size 6/7 thickness 15 mm LAT.R./MED.L	2-0210356	1
6	femoral half-wedge thickness 8 mm	2-0212308	2
7	femoral half-wedge thickness 4 mm	2-0212304	2

INSTRUMENTATION

Item	Name	Product No.	Qty
8	Trial offset connector 2mm	2-0214102	2
8	Trial offset connector 4mm	2-0214104	2
8	Trial offset connector 6mm	2-0214106	2
9	Posterior trial femoral wedge thickness 4mm	2-0214004	2
10	Posterior trial femoral wedge thickness 8mm	2-0214008	2
11	Distal trial femoral wedge thickness 4mm	2-0213904	2
12	Distal trial femoral wedge thickness 8mm	2-0213908	2
13	Offset positioner for trial tibial baseplate - 0 mm	2-0213300	1
13	Offset positioner for trial tibial baseplate - 2 mm	2-0213302	1
13	Offset positioner for trial tibial baseplate - 4 mm	2-0213304	1
13	Offset positioner for trial tibial baseplate - 6 mm	2-0213306	1
14	0 mm offset adaptator for femoral resection guide	2-0213000	1
14	2 mm offset adaptator for femoral resection guide	2-0213002	1
14	4 mm offset adaptator for femoral resection guide	2-0213004	1
14	6 mm offset adaptator for femoral resection guide	2-0213006	1
15	Trial extension stem Ø 10 length 75 mm	2-0209021	1
15	Trial extension stem Ø 12 length 75 mm	2-0209022	2
15	Trial extension stem Ø 14 length 75 mm	2-0209023	2
16	Trial extension stem Ø 10 length 100 mm	2-0209013	1
16	Trial extension stem Ø12 length 100 mm	2-0209001	2
16	Trial extension stem Ø 14 length 100 mm	2-0209004	2
16	Trial extension stem Ø 16 length 100 mm	2-0209007	2
16	Trial extension stem Ø 18 length 100 mm	2-0209010	1
16	Trial extension stem Ø 20 length 100 mm	2-0209015	1
17	Trial extension stem Ø 10 length 150 mm	2-0209014	1
17	Trial extension stem Ø 12 length 150 mm	2-0209002	2
17	Trial extension stem Ø 14 length 150 mm	2-0209005	2
17	Trial extension stem Ø 16 length 150 mm	2-0209008	2
17	Trial extension stem Ø 18 length 150 mm	2-0209011	1
17	Trial extension stem Ø 20 length 150 mm	2-0209016	1
18	Trial extension stem Ø12 length 200 mm	2-0209003	2
18	Trial extension stem Ø 14 length 200 mm	2-0209006	2
18	Trial extension stem Ø 16 length 200 mm	2-0209009	2
18	Trial extension stem Ø18 length 200 mm	2-0209012	1
18	Trial extension stem Ø20 length 200 mm	2-0209017	1

INSTRUMENTATION

SCORE® REVISION - COMMON BASIS

2-02999125

FEMUR AND TIBIA TRIALS SET

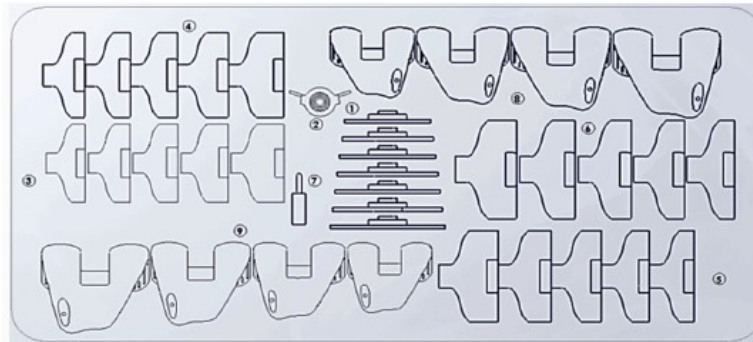

Item	Name	Product No.	Qty
1	Trial Tibial Baseplate Size 1	2-0208601	1
1	Trial Tibial Baseplate Size 2	2-0208602	1
1	Trial Tibial Baseplate Size 3	2-0208603	1
1	Trial Tibial Baseplate Size 4	2-0208604	1
1	Trial Tibial Baseplate Size 5	2-0208605	1
1	Trial Tibial Baseplate Size 6	2-0208606	1
1	Trial Tibial Baseplate Size 7	2-0208607	1
2	Delta wing for tibial trials	2-0213401	1
3	SCORE Revision Trial Insert size A thickness 10 mm	2-021421A	1
3	SCORE Revision Trial Insert size A thickness 12 mm	2-021422A	1
3	SCORE Revision Trial Insert size A thickness 14 mm	2-021423A	1
3	SCORE Revision Trial Insert size A thickness 16 mm	2-021424A	1
3	SCORE Revision Trial Insert size A thickness 20mm	2-021425A	1
4	SCORE Revision Trial Insert size B thickness 10 mm	2-021421B	1
4	SCORE Revision Trial Insert size B thickness 12 mm	2-021422B	1
4	SCORE Revision Trial Insert size B thickness 14 mm	2-021423B	1
4	SCORE Revision Trial Insert size B thickness 16 mm	2-021424B	1
4	SCORE Revision Trial Insert size B thickness 20 mm	2-021425B	1
5	SCORE Revision Trial Insert size C thickness 10 mm	2-021421C	1
5	SCORE Revision Trial Insert size C thickness 12 mm	2-021422C	1
5	SCORE Revision Trial Insert size C thickness 14 mm	2-021423C	1
5	SCORE Revision Trial Insert size C thickness 16 mm	2-021424C	1
5	SCORE Revision Trial Insert size C thickness 20 mm	2-021425C	1

INSTRUMENTATION

SCORE® REVISION - COMMON BASIS

2-02999125

FEMUR AND TIBIA TRIALS SET

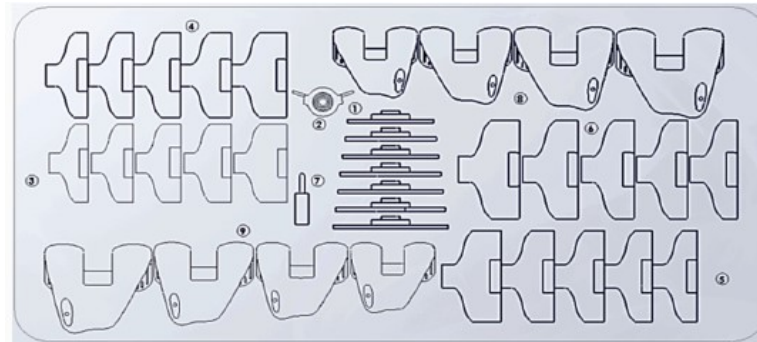

Item	Name	Product No.	Qty
6	SCORE Revision Trial Insert size D thickness 10 mm	2-021421D	1
6	SCORE Revision Trial Insert size D thickness 12 mm	2-021422D	1
6	SCORE Revision Trial Insert size D thickness 14 mm	2-021423D	1
6	SCORE Revision Trial Insert size D thickness 16 mm	2-021424D	1
6	SCORE Revision Trial Insert size D thickness 20 mm	2-021425D	1
7	Thumb knob to connect baseplate / delta wing	2-0215400	1
8	SCORE Revision femoral component - Size A Right	2-02232DA	1
8	SCORE Revision femoral component - Size B Right	2-02232DB	1
8	SCORE Revision femoral component - Size C Right	2-02232DC	1
8	SCORE Revision femoral component - Size D Right	2-02232DD	1
9	SCORE Revision femoral component - Size A Left	2-02232GA	1
9	SCORE Revision femoral component - Size B Left	2-02232GB	1
9	SCORE Revision femoral component - Size C Left	2-02232GC	1
9	SCORE Revision femoral component - Size D Left	2-02232GD	1

INSTRUMENTATION

SCORE® REVISION - COMMON BASIS

2-02999125

PATELLA AND IMPACTION SET

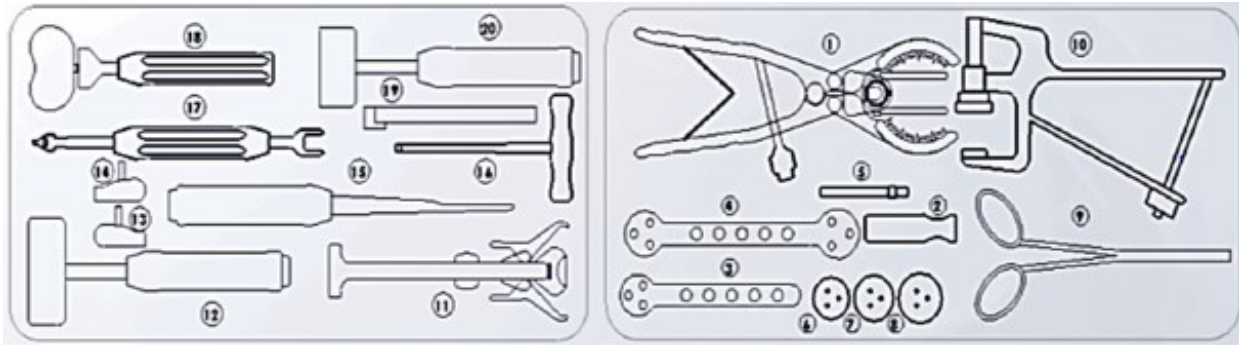

Item	Name	Product No.	Qty
1	Patellar Resection Clamp	2-0206700	1
2	Patellar resection gauge	2-0208400	1
3	Patellar Drilling Guide Ø30	2-0204900	1
4	Patellar Drilling Guide Ø33 and Ø36	2-0205000	1
5	Drill Bit for Resurfacing Patella	2-0205100	1
6	Trial resurfacing patella Ø 30	2-0205330	1
7	Trial resurfacing patella Ø 33	2-0205333	1
8	Trial resurfacing patella Ø 36	2-0205336	1
9	Clamp for Locking Ring	2-0104600	1
10	Patellar Impaction Clamp	2-0206100	1
11	Femoral condyle holder	2-0204400	1
12	Femoral component impactor	2-0204300	1
13	Offset connector left femoral impactor	2-021360G	1
14	Offset connector right femoral impactor	2-021360D	1
15	Cutting gauge	2-0206500	1
16	H5 Screwdriver	2-0200800	1
17	Stem Wrench with Universal Screwdriver H3.5	2-0215100	1
18	Tibial impactor with offset connector	2-0213700	1
19	Wrench for Offset Connector	2-0213500	1
20	Baseplate impactor	2-0203000	1

INSTRUMENTATION

SCORE® REVISION FOR PRIMARY CASES

2-0299927

TIBIAL PREPARATION/CUTTING SET

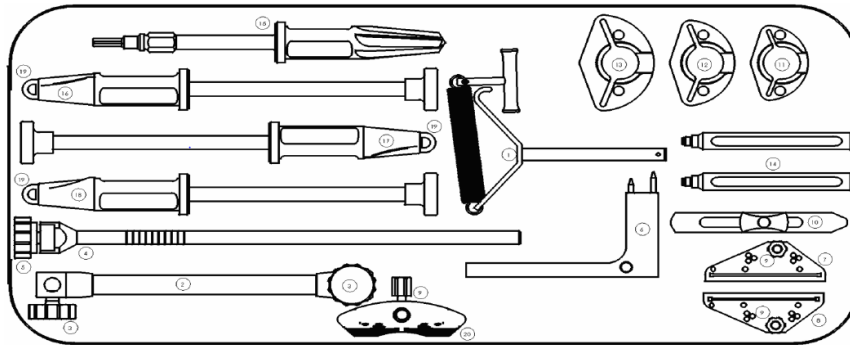

Item	Name	Product No.	Qty
1	Malleolar clamp	2-0201600	1
2	Extramedullary alignment guide	2-0201700	1
3	Wheel for extramedullary Alignment column	2-0201800	2
4	Tibial slide bar	2-0201900	1
5	Wheel for tibial bracket	2-0202100	1
6	Tibial bracket	2-0202000	1
7	Tibial resection guide RIGHT	2-0202200	1
8	Tibial resection guide LEFT	2-0202300	1
9	Wheel for resection guide	2-0203800	3
10	Tibial stylus	2-0202400	1
11	Punch guide for tibial baseplate Size 1/2	2-0202612	1
12	Punch guide for tibial baseplate size 3/4/5	2-0202635	1
13	Punch guide for tibial baseplate size 6/7	2-0202667	1
14	Removable handle for punch guide	2-0206200	2
15	Reamer for tibial extension stem	2-0202700	1
16	Punch for tibial extension stem - size 1/2	2-0202812	1
17	Punch for tibial extension stem - size 3/4/5	2-0202835	1
18	Punch for tibial extension stem - size 6/7	2-0202867	1
19	Standard trial stem	2-0208900	3
20	Revision Tibial Resection Guide	2-0210600	1

INSTRUMENTATION

SCORE® REVISION FOR PRIMARY CASES

2-0299927

FEMORAL PREPARATION/CUTTING SET

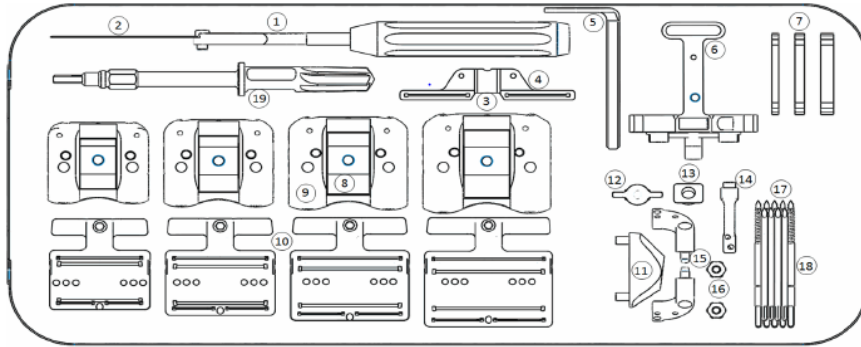

Item	Name	Product No.	Qty
1	Chisel blade handle	2-0214600	1
2	Chisel blade	2-0214500	1
3	Wheel for resection guide	2-0203800	1
4	Additional distal resection guide	2-0203700	1
5	Posterior Plate for Revision Sizing Guide	2-0222700	1
6	Revision Sizing guide	2-0222600	1
7	Femoral recutting wedge – 4 mm	2-0206004	1
7	Femoral recutting wedge - 6 mm	2-0206006	1
7	Femoral recutting wedge - 8 mm	2-0206008	1
8	Inter-condylar box trial Size A	2-021530A	1
8	Inter-condylar box trial Size B	2-021530B	1
8	Inter-condylar box trial Size C	2-021530C	1
8	Inter-condylar box trial Size D	2-021530D	1
9	Resection guide for the inter-condylar notch preparation Size A	2-022300A	1
9	Resection guide for the inter-condylar notch preparation Size B	2-022300B	1
9	Resection guide for the inter-condylar notch preparation Size C	2-022300C	1
9	Resection guide for the inter-condylar notch preparation Size D	2-022300D	1

INSTRUMENTATION

SCORE® REVISION FOR PRIMARY CASES

2-0299927

FEMORAL PREPARATION/CUTTING SET

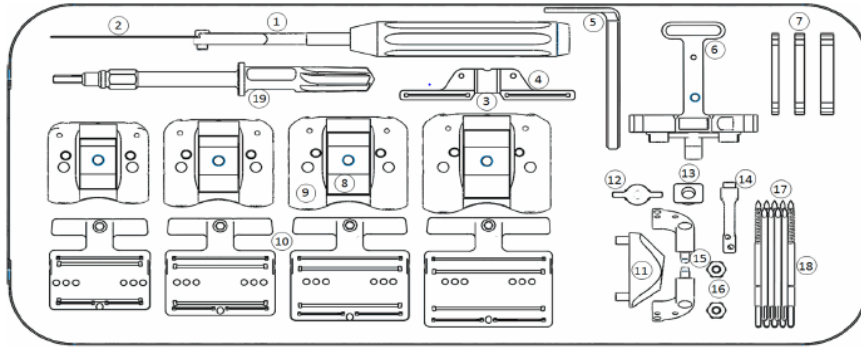

Item	Name	Product No.	Qty
10	5-in-1 Revision femoral resection guide - Size A	2-022280A	1
10	5-in-1 Revision femoral resection guide - Size B	2-022280B	1
10	5-in-1 Revision femoral resection guide - Size C	2-022280C	1
10	5-in-1 Revision femoral resection guide - Size D	2-022280D	1
11	Femoral Reamer Guide	2-0214900	1
12	Anterior femoral stylus	2-0203400	1
13	Valgus Alignment Guide 6°	2-0203306	1
14	Femoral resection guide stabilizer	2-0217800	1
15	LM/RL bracket for 5 in 1 Revision Femoral resection guide	2-0222901	1
15	RM/LL bracket for 5 in 1 Revision Femoral resection guide	2-0222902	1
16	Drill guide for pin Ø 4	2-0203500	2
17	Headless pin length 80 mm	2-0201400	4
18	Threaded pin Ø4 length 90 mm	2-0200901	5
19	Femoral reamer	2-0215000	1

INSTRUMENTATION

MEDIUM SAW BLADES

SYNTHES AO / SODEM medium Saw Blade

Sterile Product No. 2-0228001

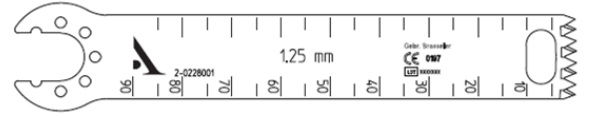

STRYKER medium Saw Blade

Sterile Product No. 2-0228002

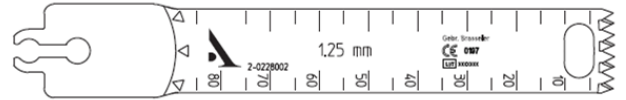

ZIMMER / HALL / LINVATEC medium Saw Blade

Sterile Product No. 2-0228003

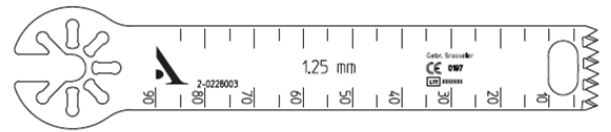

NOTES

Customer Service-France:

Porte du Grand Lyon,
01700 Neyron, France
Phone: +33 (0)4 37 85 19 19
Fax: +33 (0)4 37 85 19 18

Email: amplitude@amplitude-ortho.com

Customer Service-Export:

11, cours Jacques Offenbach. ZA Mozart 2,
26000 Valence, France
Phone: +33 (0)4 75 41 87 41
Fax: +33 (0)4 75 41 87 42

Website: www.amplitude-ortho.com