



Surgical technique

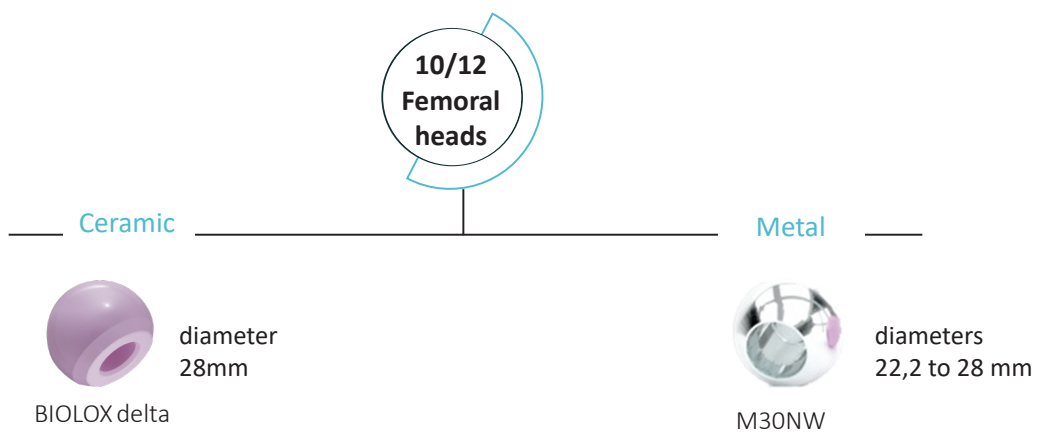
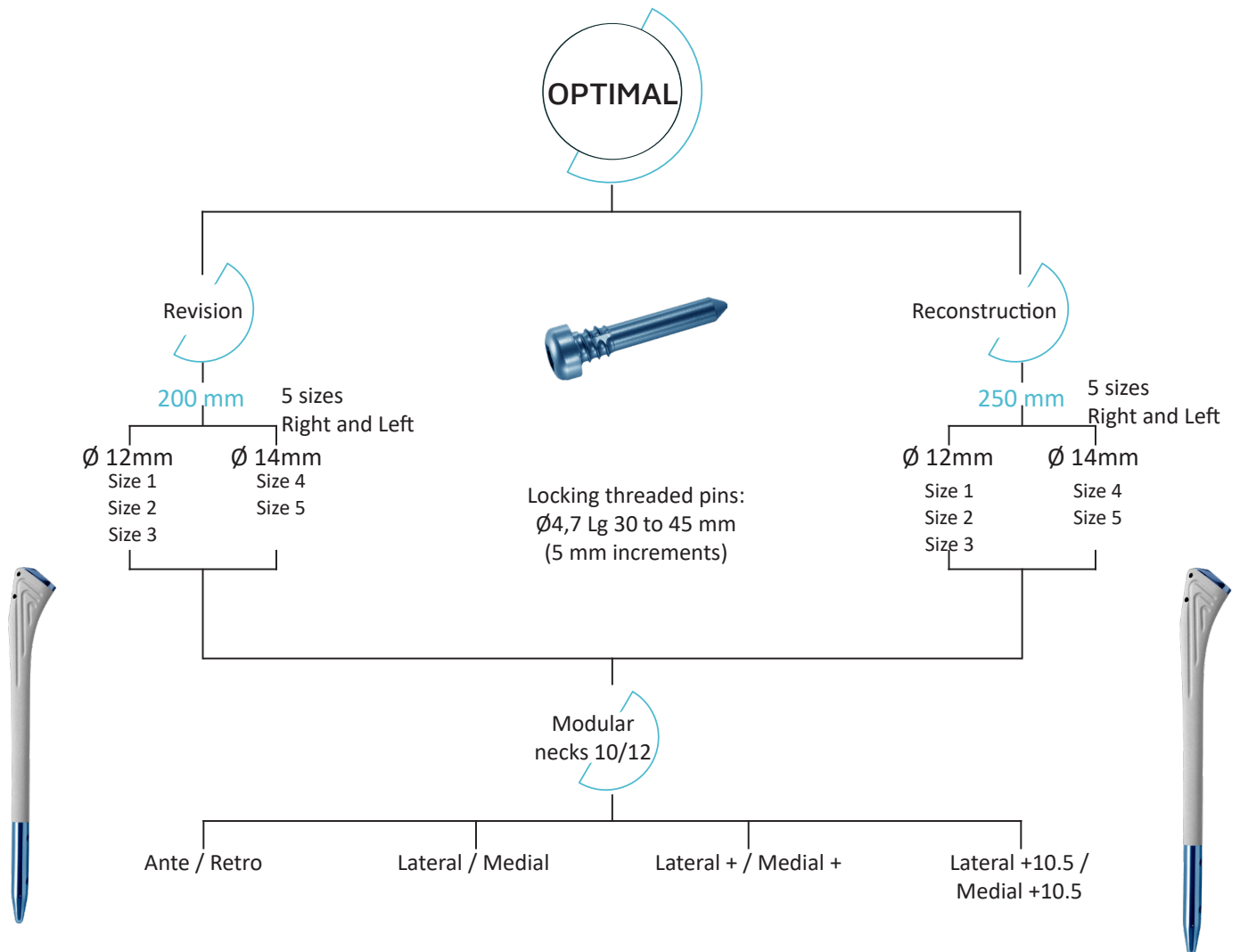

Table of contents

Concept and range.....	5
Summary of surgical technique.....	8
Step 1- Pre-operative planning.....	10
Step 2- Femoral shaft preparation.....	11
Step 3- Greater trochanter preparation.....	12
Step 4- Medullary canal preparation.....	13
Step 5- Extra-medullary trials.....	14
Step 6- Implanting the final stem: non-locking version.....	16
Step 7- Implanting the head and neck: non-locking version.....	17
Step 8- Implanting the final stem: locking version.....	18
Step 9- Locking the final stem: locking version.....	19
Step 10- Implanting the head and neck: locking version.....	21
Step 11- Implant extraction.....	22
Step 12- Postoperative X-rays.....	23
Instrumentation.....	25
Appendix A: recommendations.....	30



Concept and range



Concept and range

The OPTIMAL stem is a cementless femoral stem indicated* for revision and femoral reconstruction cases. It is an anatomical stem with a modular neck to be assembled. It can be locked with up to 2 threaded pins. It is available in two lengths: 200 mm and 250 mm.

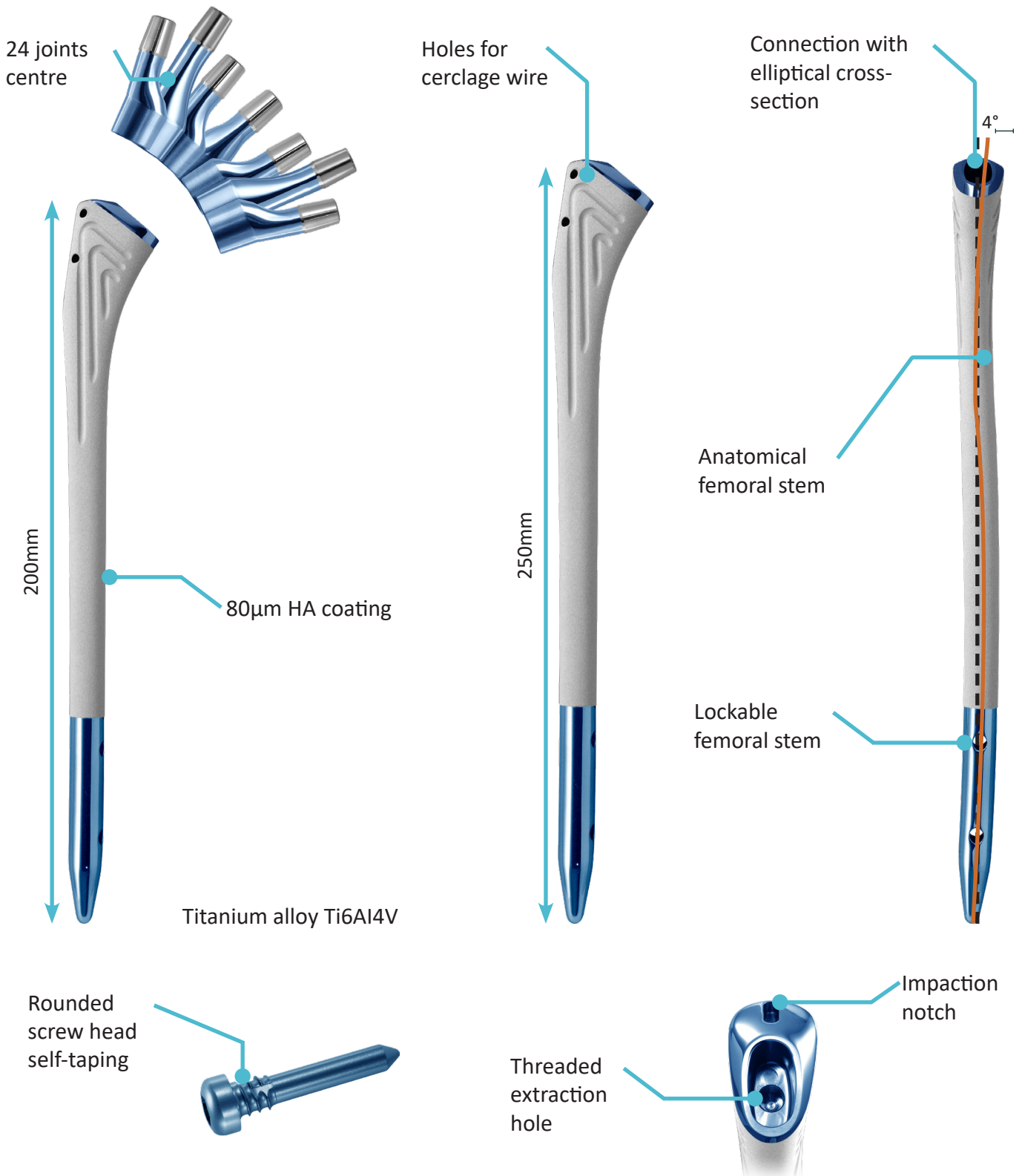

*The indications and contraindications are described in the IFU provided with this device.





Summary of surgical technique

If the stem is not locked:

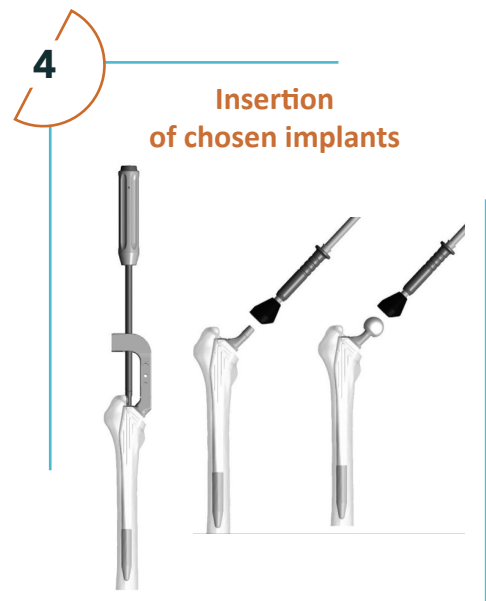
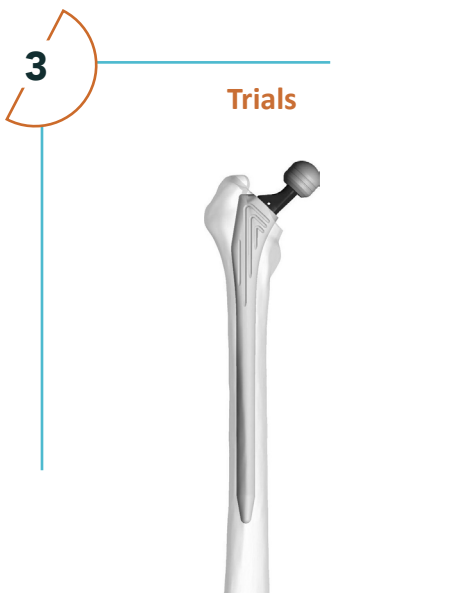
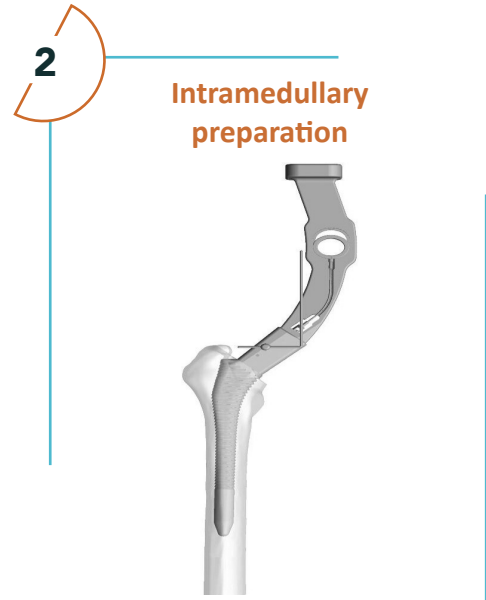
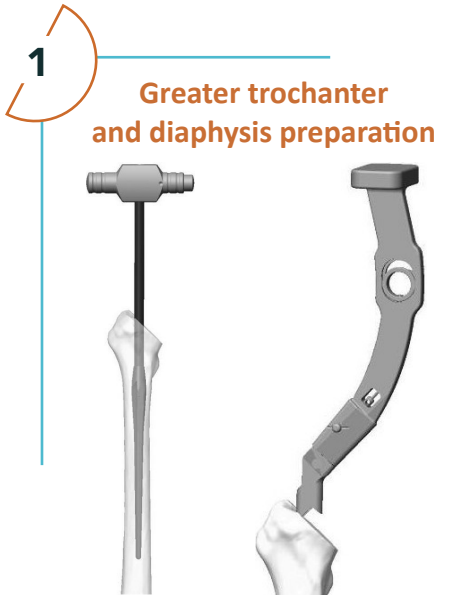

Summary of surgical technique

If the stem is locked:

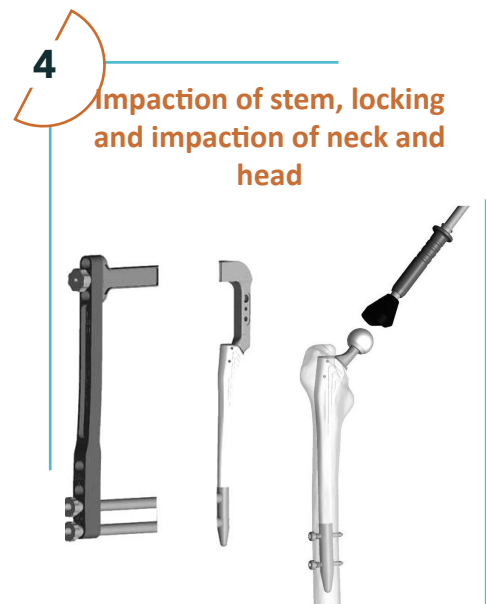
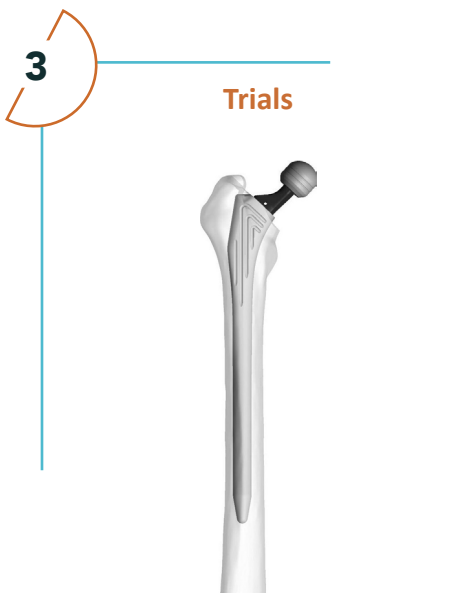
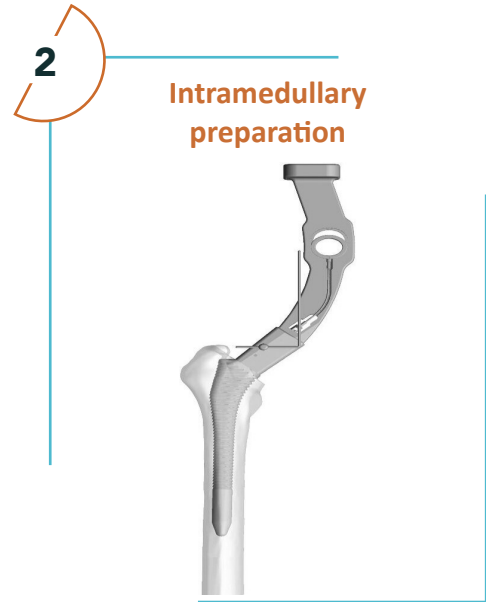

IMPORTANT

Refer to recommendations on page 30 to ensure proper stem locking

1 Pre-operative planning



Pre-operative planning is an important step to determine the implant size most adapted to restore the patient's anatomy. The provided templates are superimposed over X-rays to:

- Evaluate the metaphyseal bone loss ;
- Locate the joint centre and infer the position of the replacement femoral head centre ;
- Decide on a reliable bony landmark, which can be identified intra-operatively, that will be used to identify the joint centre. This landmark will be used throughout the procedure to recreate the joint centre's position ;
- Estimate the size and length of the femoral stem to be implanted.

After having approached and exposed the existing implants, but before extracting the existing femoral stem, the bony landmark (e.g. greater trochanter, lesser trochanter, fracture line, femorotomy line, wire cerclage or a user-created landmark) selected during the preoperative planning will have to be confirmed.

REMINDER

The purpose of this surgical technique description is to provide instructions on how to use the instrumentation properly. The surgeon is fully responsible for choosing and performing the approach and surgical technique.

NOTE

Templates are provided at 115% scale. Other magnifications and digital templates are available on request.

2 Femoral Shaft Preparation

Place the reaming guide in the medullary canal.

Assemble the smallest reaming head (9 mm diameter) on the flexible drive shaft and slide the entire unit on the reaming guide. Assemble the power tool onto the drive shaft.

Ream the intramedullary canal using sequentially larger reaming heads (1 mm increments) until the reamer makes contact with the cortex. The goal is to achieve press-fit over a major proportion of the shaft to provide good implant stability without the threaded pins. The diameter of the final reaming head should be 2 mm greater than the diameter of the stem being implanted.



3 Greater Trochanter Preparation

Assemble the removable handle with the trochanter reaming guide and stabilise the entire unit in the femoral shaft.

Remove the handle and push the trochanter reamer onto the guide.

The trochanter is prepared manually using the reamer holder.

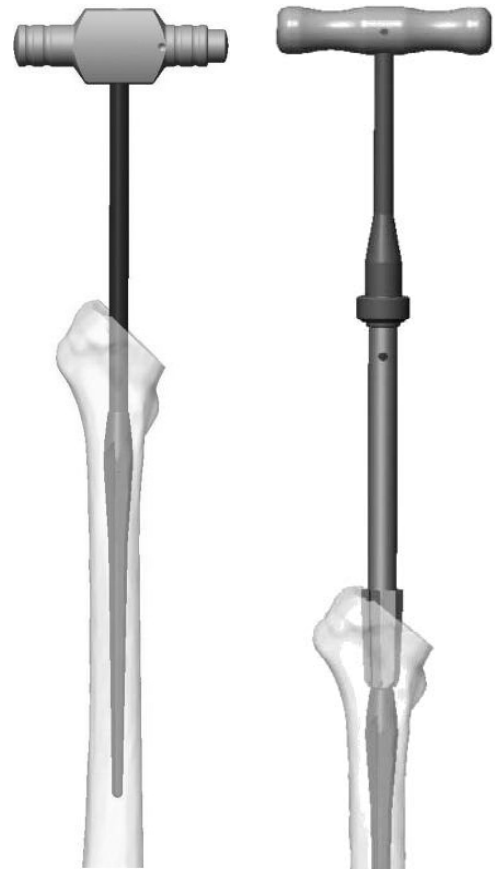

NOTE

The trochanter can also be prepared using a box chisel assembled on the broach handle.

4 Medullary Canal Preparation

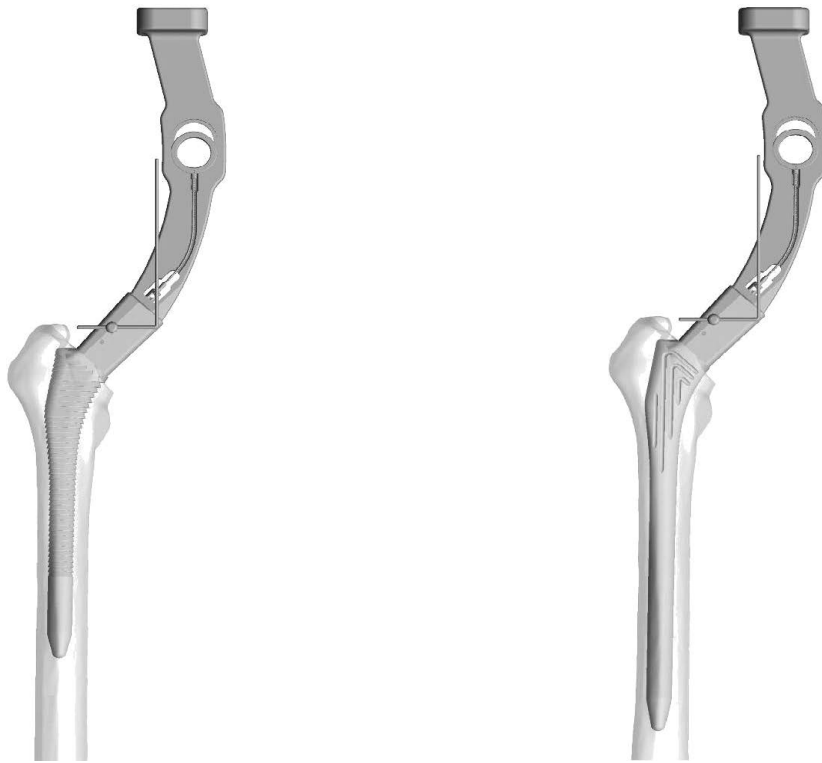

Assemble the femoral broach corresponding to the operated side on the broach handle (grey broaches for left side and yellow broaches for right side).

Start with the size 1 broach and push it down into the femoral shaft; change to the next size up and repeat the procedure until satisfactory metaphyseal filling and stability are achieved. Check the depth by placing the blunt K-wire on the broach handle. This allows to check the horizontal projection of a medium neck femoral head against the previously selected bony landmark per-operatively. This will ensure it matches the height defined during planning.

If the 200-mm long stem is being implanted: leave the final broach used in the femur to act as a trial implant and remove the broach handle.

If the 250-mm long stem is being implanted: remove the final broach used and replace it with the 250-mm long trial stem of the same size and side as the last broach. Place the trial stem onto the broach handle and push it into the femur, making sure not to force it in. The trial stem must be allowed to position itself. Check the depth using the blunt K-wire and remove the broach handle.

REMINDER

The final reamer must be 2 mm larger than the diameter of the stem being implanted.

NOTE

As progressively larger broaches are being used, make sure the reamed diameter corresponds to the broach's distal diameter. Refer to page 5 for the available stems diameters.

5 Extra-medullary Trials

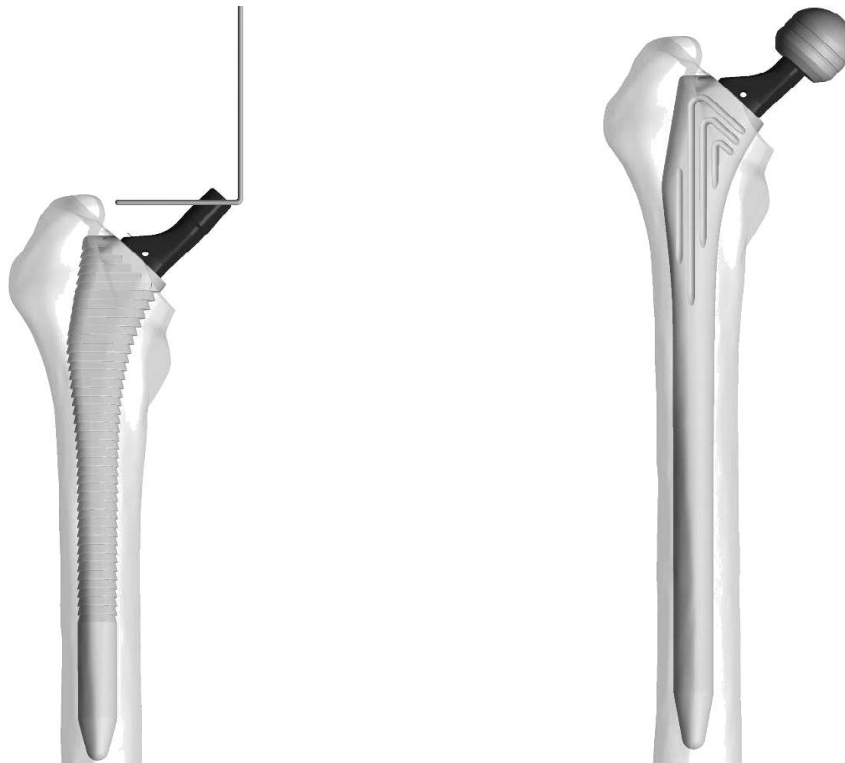

Place the LATERAL trial modular neck (blue neck) onto the broach or trial stem.

Select and place a trial head of the desired length and diameter onto the neck.

Reduce the joint using the modular neck-head impactor assembled on the universal handle. Perform stability and range of motion trials, and check leg length to validate the extramedullary settings.

If settings are unsatisfactory, perform the trials again with different trials (modular necks, heads) until the most appropriate trial modular neck and head are found to achieve the desired correction. Remove the selected trial head and modular neck.

Use the broach handle to extract the broach or trial femoral stem.

Keep the selected components together (broach or trial stem with trial modular neck and trial head) to remember the chosen combination until the final implant is ready.

Color coding for trial heads:

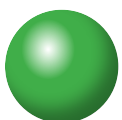

Ø22.2mm

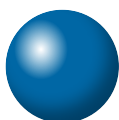

Ø28mm

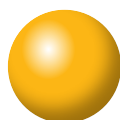

Ø32mm



Ø36mm



Short
Neck

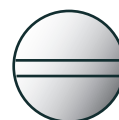

Medium
Neck



Long
Neck



Extra-long
Neck

IMPORTANT

Please comply with the following recommendations on acceptable modular neck/head combinations.

		FEMORAL HEAD				
		Short neck	Medium neck	Long neck	Extra-Long neck	
MODULAR NECKS	L/M neck	Lateral and Medial position	✓	✓	✓	✗
	Anté/Rétro neck	anteverted and retroverted position	✓	✓	✓	✓
	L+/M+ neck	Lateral position	90Kg max. patient weight	90Kg max. patient weight	90Kg max. patient weight	✗
		Medial position	✓	✓	✓	✗
	L+10,5/ M+10,5 neck	Lateral and Medial position	90Kg max. patient weight	90Kg max. patient weight	✗	✗

Table: femoral heads / modular necks combinations.

6 Implanting the Final Stem

Non-locking version



Remove the protective elastomer cap from the oblong opening on the stem.

Assemble the implant holder with the selected stem using the spherical tip and universal handle. **Make sure everything is tight.**

To ensure the stem is properly aligned when it is impacted into the femur, align the impactor carefully on the implant holder before impaction. A groove on the implant holder indicates the height of the centre rotation with a medium femoral head and a Lateral modular neck. Check that the depth matches the one planned before the surgery.

Unscrew the implant holder.

Place the trial modular neck on the stem to validate the joint stability and range of motion. If these are unsatisfactory, change the trial neck.

Check the height of the replacement head centre relative to the anatomical landmark by placing the blunt K-wire in the slot on the trial neck, which indicates the height of the centre with a medium femoral head and a Lateral modular neck.

7 Implanting the Head and Neck

Non-locking version

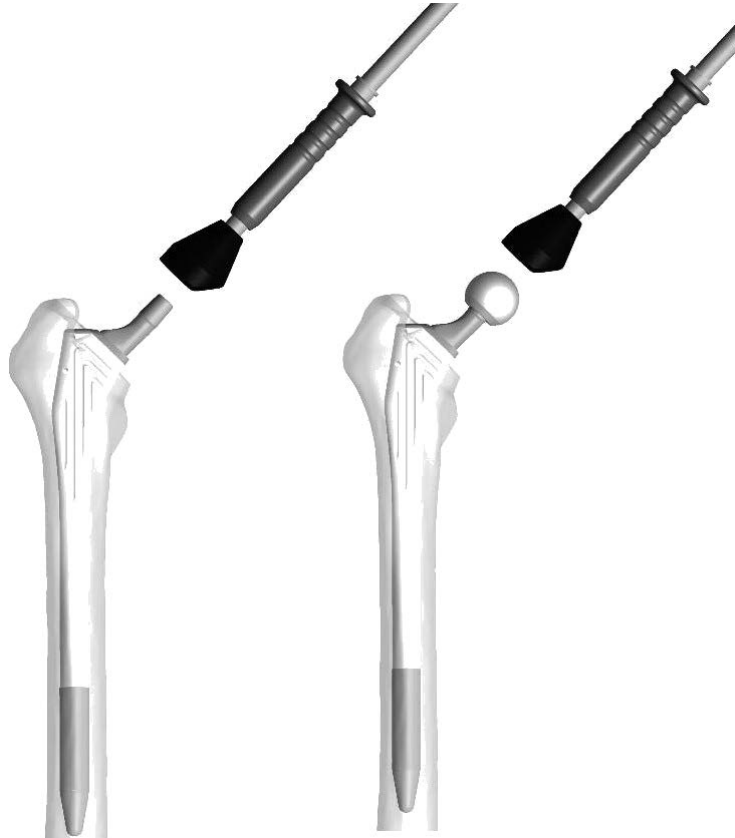

Place the selected modular neck into the oblong opening, while maintaining the position validated during the trials and according to the trial implants kept on the back table.

Impact the modular neck using the head-neck impactor assembled on the universal handle. The impactor has a cavity where the proximal part of the modular neck is inserted.

Place the selected head onto the neck, then impact it with the head-neck impactor assembled on the universal handle. Reduce the joint.

IMPORTANT

Make sure the connection between the stem and modular neck is clean and completely dry. The condition of the oblong Morse taper on the stem must be carefully inspected before inserting the modular neck. If the taper is damaged, the modular stem itself must be extracted and replaced.

8 Implanting the Final Stem

Locking version

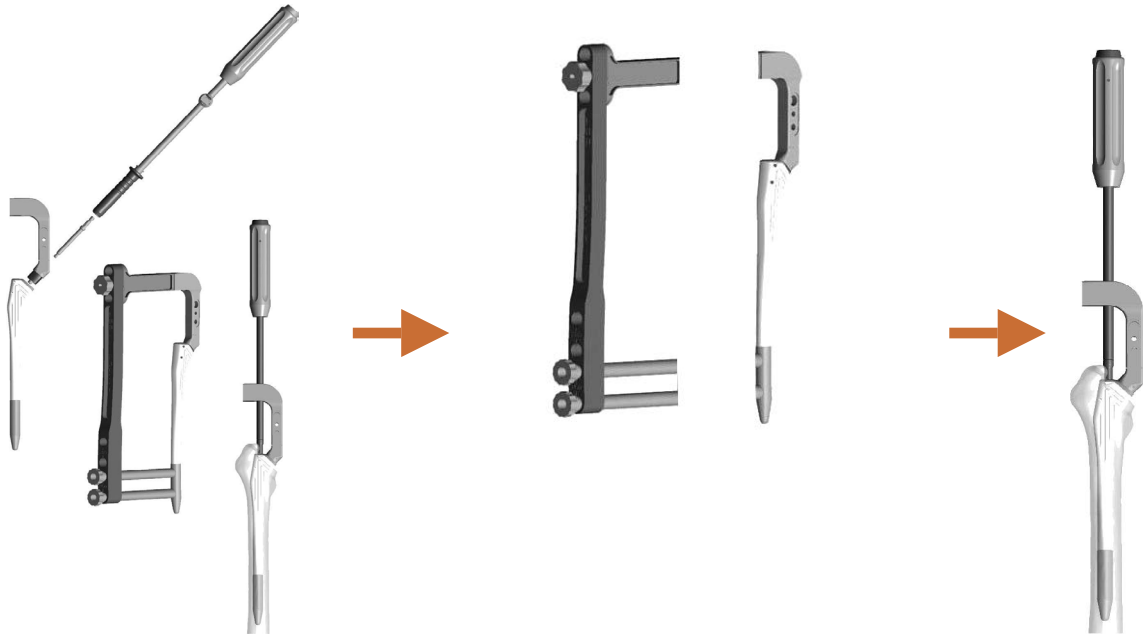

On the back table:

Remove the protective elastomer cap from the oblong opening on the stem.

Assemble the implant holder with the selected stem using the spherical tip and universal handle. **Make sure everything is tight.**

Mount the offset shaft onto the alignment guide corresponding to the operated side, tighten everything with the clamping screw and then position the entire unit on the implant holder.

Make sure the drilling barrels and drill bits placed in the guide are aligned with the locking holes on the stem's shaft. The drilling level is indicated on the guide relative to the length of the stem being implanted.

Remove the alignment guide and the offset shaft from the implant holder.

On the patient:

Align the impactor on the implant holder and then impact the stem into the femur. A groove on the implant holder indicates the height of the centre of the femoral head with medium collar and lateralised neck. Verify that the depth matches the one planned before the surgery.

9 Locking the Final Stem

Locking version

Once the stem is in place, put the offset shaft and drilling alignment guide back into the implant holder.

Secure everything together with the clamping screw.

Locate the two selected drilling levels on the alignment guide.

Install the two drilling barrels. Place the blunt drill guide in the proximal hole on the alignment guide.

Use a scalpel to make an incision in the skin then the fascia lata. **A wider incision should be made to make it easier to pass instruments.**

Push the blunt drill guide until it touches the bone. Remove the guide.

Make sure the barrel touches the bone.

Drill the proximal hole through both cortices using drill bit No. 1 for threaded pins. Leave the bit in place to stiffen the construct.

Place the blunt drill guide in the distal hole on the drilling alignment guide. Make an incision through the skin and fascia lata. Push the blunt drill guide until it touches the bone. Remove the guide.

Make sure the barrel touches the bone.

Drill the proximal hole through both cortices using drill bit No. 2 for threaded pins.

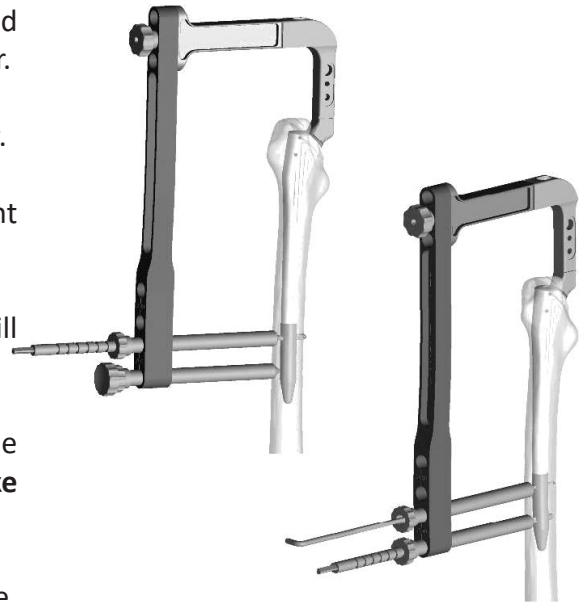

NOTE

A small incision can also be made to check the drilling barrels touch the femoral cortex.

9 Locking the Final Stem

Locking version

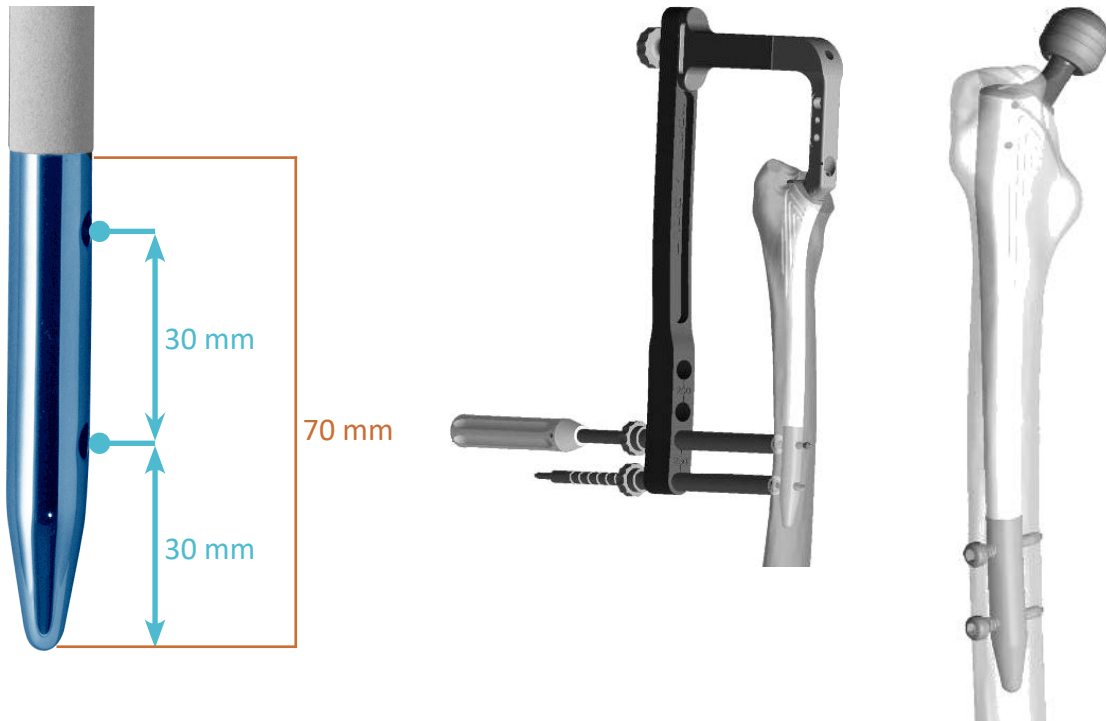

Remove the proximal drill bit and use the threaded pin size gauge to determine the length of the threaded pin needed. The threaded pin is then inserted with the short H5 screwdriver (for stem locking). Continue turning the screw until the mark on the screwdriver is flush with the drilling barrel.

The second threaded pin is inserted the same way, except that the long H5 screwdriver is used.

Remove the stem locking frame (offset shaft, alignment guide and screw) and implant holder using the spherical tip and universal handle.

Place the trial modular neck on the stem to validate the joint stability and range of motion. If these are unsatisfactory, change the trial neck.

Check the height of the replacement head centre relative to the anatomical landmark, by placing the blunt K-wire in the slot on the trial neck ; the horizontal projection of the femoral head centre corresponds to the blunt K-wire and to a Lateral modular neck with medium head.

10 Implanting the Head and Neck

Locking version

IMPORTANT

Make sure the connection between the stem and modular neck is clean and completely dry. The condition of the oblong Morse taper on the stem must be carefully inspected before inserting the modular neck. If the taper is damaged, the modular stem itself must be extracted and replaced.



Place the selected modular neck into the oblong opening, while maintaining the position validated during the trials and in accordance with the trial implants kept on the back table.

Impact the modular neck using the head-neck impactor mounted on the universal handle. The impactor has a cavity where the proximal part of the modular neck is inserted.

Use the head gripping tip to place the selected head onto the neck, then impact it with the head-neck impactor mounted on the universal handle. Reduce the joint.

11 Implants extraction

The modular neck

Remove the femoral head by tapping around the underside of the head.

Place the neck disconnecter over the modular neck, making sure the disconnecter's mobile shaft is located just above the taper of the femoral head.

Tighten the mobile shaft with the H5 spherical tip mounted on the universal handle.

Assemble the reamer holder on top of the disconnecter.

Hold the disconnecter with the 19 wrench and use the reamer holder to turn it until the neck is extracted.



The stem

Once the modular neck has been extracted, screw the modular femoral stem extractor into the oblong opening on the stem using the H5 spherical tip mounted onto the universal handle.

Make sure the extractor is aligned with the stem axis.

Place the shaft and slap hammer cylinder on the femoral stem extractor and then extract the stem. Keep the slap hammer aligned with the stem axis during extraction.

NOTE

If the stem has been locked, extract the threaded pins with the H5 screwdriver for OPTIMAL stem locking before attempting to extract the stem.



12 Postoperative X-rays

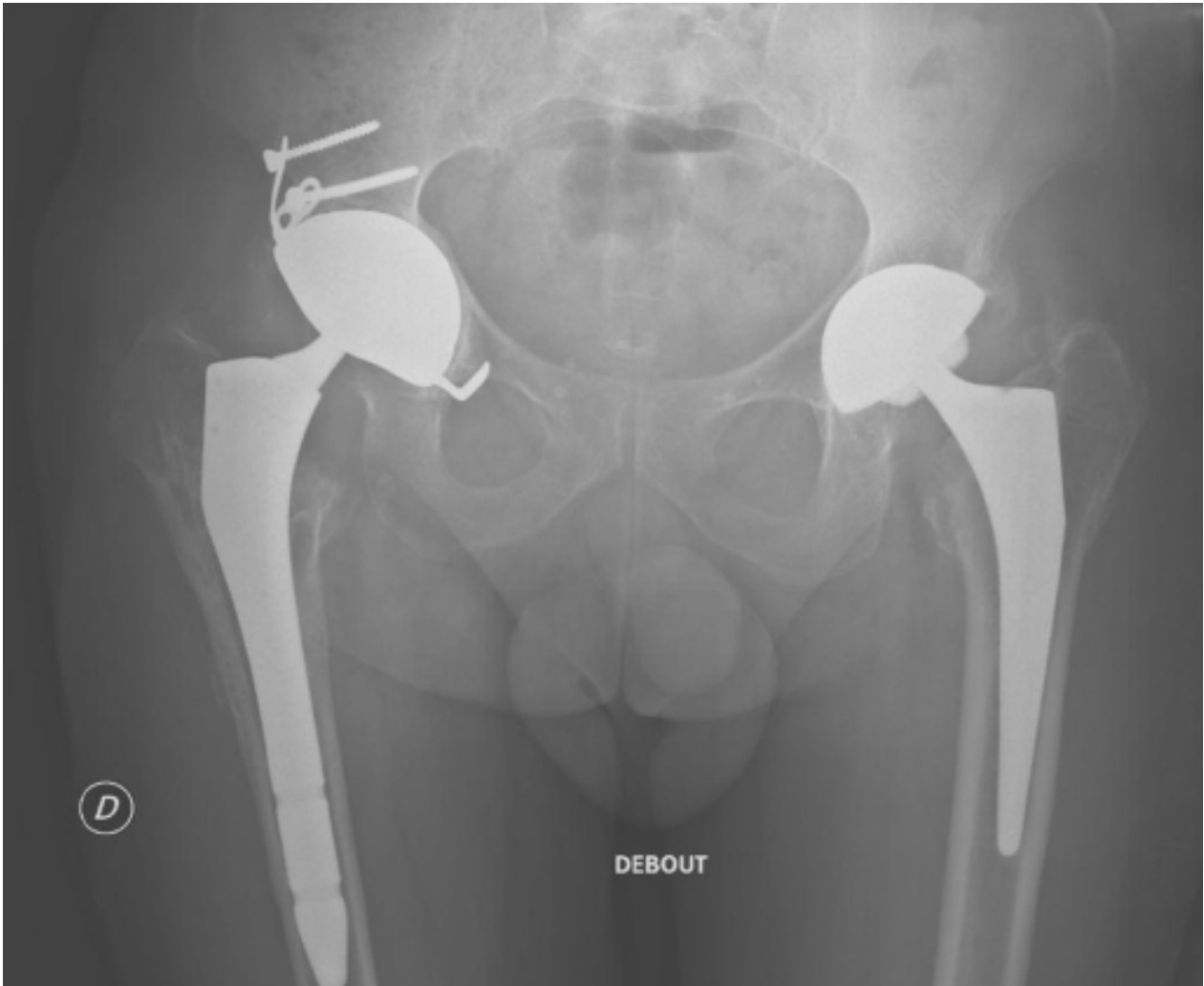



Instrumentation

Femoral preparation set

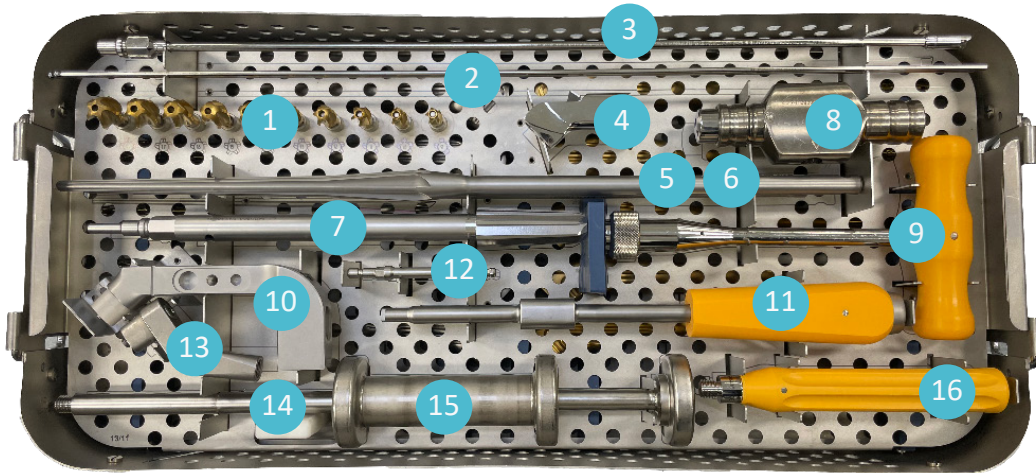

Item	Description	Reference	Qty
1	Reaming head $\varnothing 9$ mm to $\varnothing 18$ mm	MAL3190090NT MAL31900180NT	1 of each
2	Flexible drive shaft Nitinol	MAF21900180NT	1
3	Reamer guide Wire for flexible reamers - $\varnothing 3$ Length 500 mm	2-0197300	2
4	Box chisel - Size M	2-0116300	1
5	Canal finder for trochanteric reamer 12x10	2-0197012	1
6	Canal finder for trochanteric reamer 18x10	2-0197018	1
7	Trochanteric reamer	2-0110900	1
8	Removable handle	2-0109300	1
9	Reamer handle	2-0103500	1
10	OPTIMAL stem prosthesis handle	2-0196300	1
11	OPTIMAL stem impactor/alignment guide	2-0196200	1
12	Spherical tip H5	2-0115700	1
13	Modular femoral stem extractor	2-0196900	1
14	Slap hammer shaft	2-0102900	1
15	Slap hammer weight	2-0103300	1
16	Holding handle	2-0104200	1

Instrumentation

Trial stem set



Item	Description	Reference	Qty
1	Trial OPTIMAL stem - Size 1 Ø 12 Right - 250mm	2-0195901	1
1	Trial OPTIMAL stem - Size 2 Ø 12 Right - 250mm	2-0195902	1
1	Trial OPTIMAL stem - Size 3 Ø 12 Right - 250mm	2-0195903	1
1	Trial OPTIMAL stem - Size 4 Ø 14 Right - 250mm	2-0195904	1
1	Trial OPTIMAL stem - Size 5 Ø 14 Right - 250mm	2-0195915	1
2	Trial OPTIMAL stem - Size 1 Ø 12 Left - 250mm	2-0196001	1
2	Trial OPTIMAL stem - Size 2 Ø 12 Left - 250mm	2-0196002	1
2	Trial OPTIMAL stem - Size 3 Ø 12 Left - 250mm	2-0196003	1
2	Trial OPTIMAL stem - Size 4 Ø 14 Left - 250mm	2-0196004	1
2	Trial OPTIMAL stem - Size 5 Ø 14 Left - 250mm	2-0196015	1

Instrumentation

Trial head and neck set

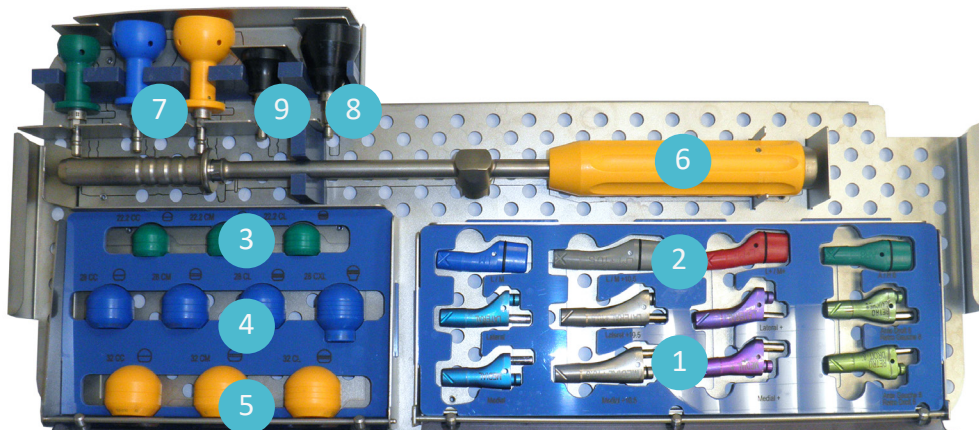

Item	Description	Reference	Qty		
1	Trial modular neck on broach - LATERAL	2-0116401	1		
	Trial modular neck on broach - MEDIAL	2-0116402			
	Trial modular neck on broach - LATERAL PLUS	2-0116403			
	Trial modular neck on broach - MEDIAL PLUS	2-0116404			
	Trial modular neck on broach - ANTE GAUCHE / RETRO DROIT 8°	2-0116405			
	Trial modular neck on broach - ANTE DROIT / RETRO GAUCHE 8°	2-0116406			
	Trial modular neck on broach - LATERAL +10.5	2-0116409			
	Trial modular neck on broach - MEDIAL +10.5	2-0116410			
	2	Trial modular neck on stem - LATERAL / MEDIAL		2-0116101	1
		Trial modular neck on stem - ANTE / RETRO 8°		2-0116102	
Trial modular neck on stem - LATERAL PLUS / MEDIAL PLUS		2-0116103			
Trial modular neck on stem - LATERAL / MEDIAL +10.5		2-0116105			
3	Trial head on stem Ø 22.2 short neck	2-0100405	1		
	Trial head on stem Ø 22.2 medium neck	2-0100406			
	Trial head on stem Ø 22.2 long neck	2-0100407			
4	Trial head on stem Ø 28 short neck	2-0100401	1		
	Trial head on stem Ø 28 medium neck	2-0100402			
	Trial head on stem Ø 28 long neck	2-0100403			
	Trial head on stem Ø 28 extra long neck	2-0100404			
5	Trial head on stem Ø 32 short neck	2-0100408	1		
	Trial head on stem Ø 32 medium neck	2-0100409			
	Trial head on stem Ø 32 long neck	2-0100410			
6	Universal Handle - conventional / navigated	2-0117600	1		
7	Femoral head gripping tip Ø 22.2	2-0104322	1		
	Femoral head gripping tip Ø 28	2-0104328			
	Femoral head gripping tip Ø 32	2-0104332			
8	Femoral head and modular neck impactor	2-0115800	1		
9	Impactor for Ø 22.2 heads	2-0101400	1		

Instrumentation

Broach set

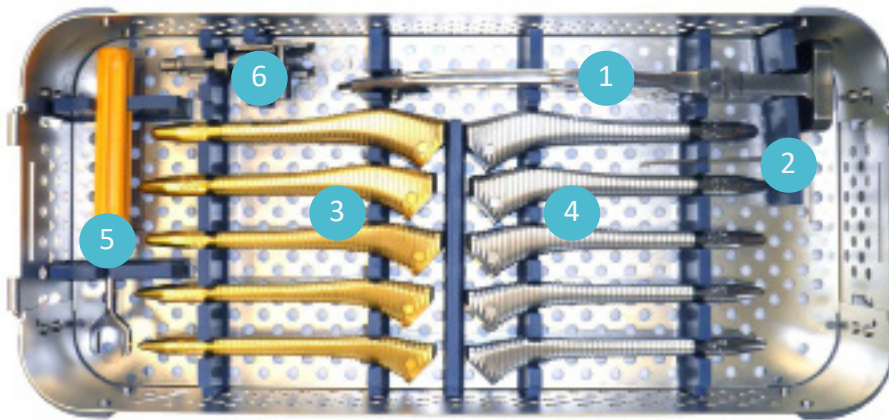

Item	Description	Reference	Qty
1	Straight broach handle conventional/navigated	2-0116901	1
2	Alignment pin Ø 2 A/P	2-0114000	1
3	OPTIMAL femoral broach - Size 1 Ø 12 Right - 200mm	2-0195701	1
	OPTIMAL femoral broach - Size 2 Ø 12 Right - 200mm	2-0195702	
	OPTIMAL femoral broach - Size 3 Ø 12 Right - 200mm	2-0195703	
	OPTIMAL femoral broach - Size 4 Ø 14 Right - 200mm	2-0195704	
	OPTIMAL femoral broach - Size 5 Ø 14 Right - 200mm	2-0195715	
4	OPTIMAL femoral broach - Size 1 Ø 12 Left - 200mm	2-0195801	1
	OPTIMAL femoral broach - Size 2 Ø 12 Left - 200mm	2-0195802	
	OPTIMAL femoral broach - Size 3 Ø 12 Left - 200mm	2-0195803	
	OPTIMAL femoral broach - Size 4 Ø 14 Left - 200mm	2-0195804	
	OPTIMAL femoral broach - Size 5 Ø 14 Left - 200mm	2-0195815	
5	Wrench 19 mm	2-0118400	1
6	Modular neck extractor	2-0116200	1

Instrumentation

Locking set

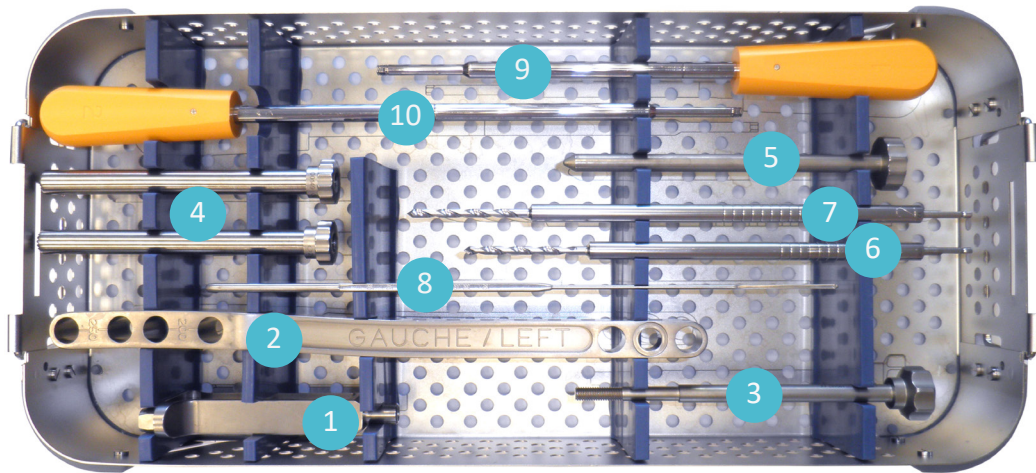

Item	Description	Reference	Qty
1	Offset shaft for OPTIMAL stem	2-0196400	1
2	Drilling alignment guide for OPTIMAL stem	2-0196700	1
3	Clamping screw for OPTIMAL stem drilling alignment guide	2-0196500	1
4	Drilling tube	2-0109600	2
5	Blunt drill guide	2-0110600	1
6	Drill bit No. 1 for OPTIMAL threaded pin	2-0196600	1
7	Drill bit No. 2 for OPTIMAL threaded pin	2-0198000	1
8	OPTIMAL threaded pin gauge	2-0197700	1
9	Screwdriver for OPTIMAL locking - H5 - Short	2-0197800	1
10	Screwdriver for OPTIMAL locking - H5 - Long	2-0197900	1

Appendix A: recommendations

Stem impaction and orientation

When implanting the stem, **do not impact the frame while it is mounted on the stem** as this may **jeopardise the alignment of the drilling barrels** (drill bits) with the holes in the stem.

The frame **must be disassembled** after the trials on the back table and re-assembled after stem impaction. **Striking force should only be applied through the provided impactor.**

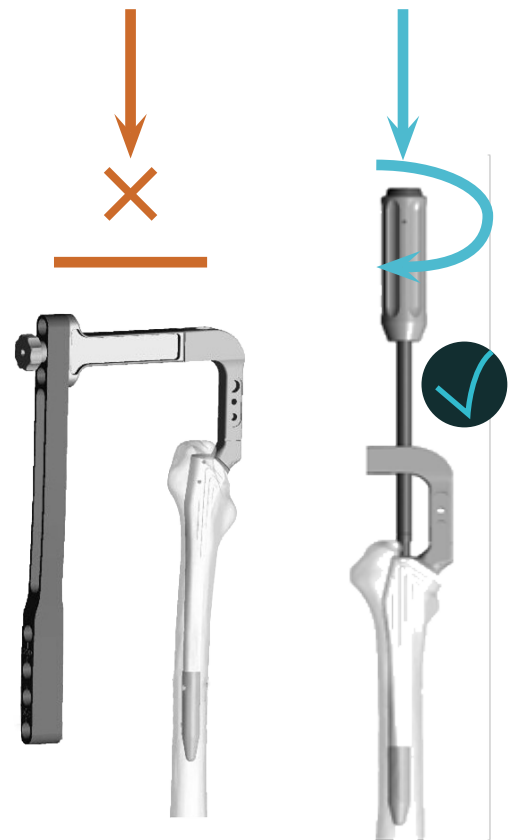

Recommendations concerning the drilling step

It is **essential to use both drill bits from the instrumentation set** to make the holes where the threaded pins will be inserted. Leave drill bit No. 1 in place to stiffen the construct proximally and drill the second hole using drill bit No. 2, making sure to cross both cortices each time. Leave drill bit No. 2 in place while assembling the first threaded pin.

Avoid putting pressure on the frame during drilling as this could misalign the drill bit and jeopardise the frame's correct alignment.

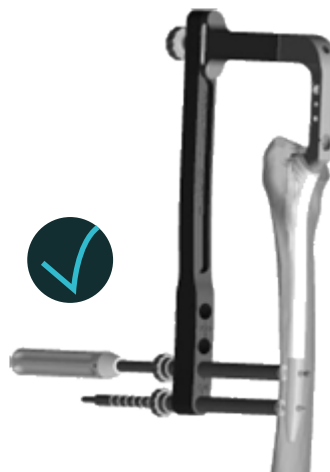
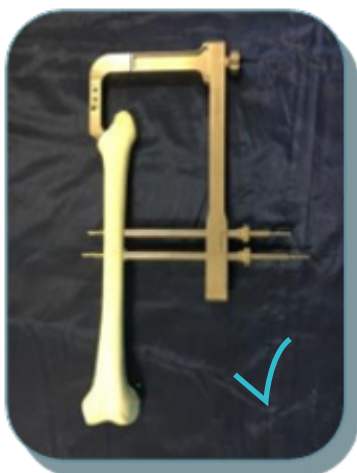



The products availability may vary by country. Please check with your local representative for availability.

Service Clients – France :

Porte du Grand Lyon,
01700 Neyron – France
Tél. : **+33 (0)4 37 85 19 19**
Fax : +33 (0)4 37 85 19 18
E-mail : amplitude@amplitude-ortho.com

Customer Service – Export :

11, cours Jacques Offenbach,
ZA Mozart 2,
26000 Valence – France
Tél. : **+33 (0)4 75 41 87 41**
Fax : +33 (0)4 75 41 87 42

www.amplitude-ortho.com