

score  
score AS

amplitude



## Surgical Technique

Primary total knee system  
Mobile bearing - cemented or cementless  
4-in-1 Conventional Instrumentation



# Summary

Introduction .....	4
Score / Score AS Implant .....	5
Surgical Technique Overview .....	11
1 - Pre-operative planning .....	14
2 - Distal femoral resection .....	15
3 - Intra-medullary guide .....	18
Extra-medullary guide .....	19
4 - Combined tibial guide .....	20
5 - Tibiale resection .....	21
6 - Extension and flexion gaps .....	22
7 - Femoral resections .....	25
8 - Femoral preparation .....	27
9 - Tibial preparation .....	28
10 - Patella preparation: patellar resection option .....	29
11 - Patella preparation: patellar reaming option .....	30
12 - Definitive implants .....	31
Option: Tibial augment, tibial extension stem and offset adapter .....	32
Instrumentation .....	37
Appendix A .....	49
Appendix B .....	50

---

# Introduction

- This surgical technique is related to the SCORE instrument set and the 4-in-1 femoral cutting instrument set which allow the SCORE Total Knee Prosthesis to be fitted.
- The instrumentation can be used:
  - in conventional (mechanical) version
  - in Computer-Assisted Surgery version (by adding the AMPLIVISION Navigation Set)
  - with the i.M.A.G.E. Patient Specific Instrumentation (by adding the i.M.A.G.E. 4-in-1 for TKA set).

Not all devices presented in this Surgical Technique may be registered in your country. Please contact your Amplitude Sales Representative for availability.





# Implant score / score AS

- The SCORE/SCORE Allergy Solution (AS) TKS is a PCL-sacrificing and mobile bearing implant for primary knee arthroplasty.
- The stability is provided by sagittal and frontal congruency through the extension to the flexion.
- The SCORE TKS is available in cemented or cementless versions, .
- The SCORE AS TKS is coated with Titanium Nitride (TiN) ceramic to minimise allergic reactions. It is only available in cemented version.



# Femoral component

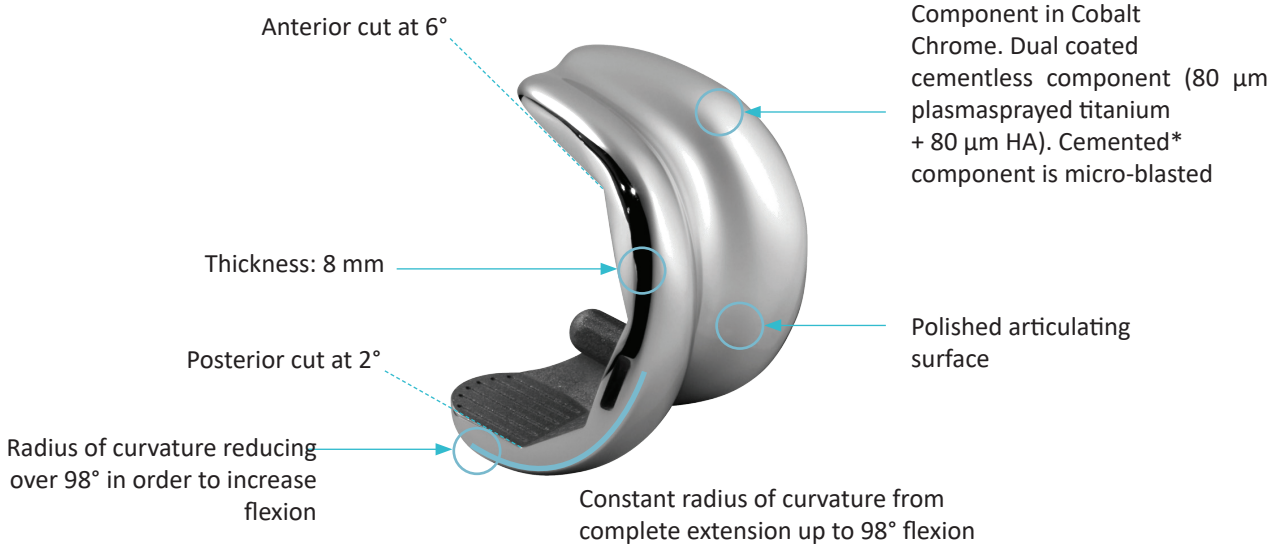

\*Cobalt Chrome SCORE AS femoral component coated with Titanium Nitride (TiN)  
Cemented version only.

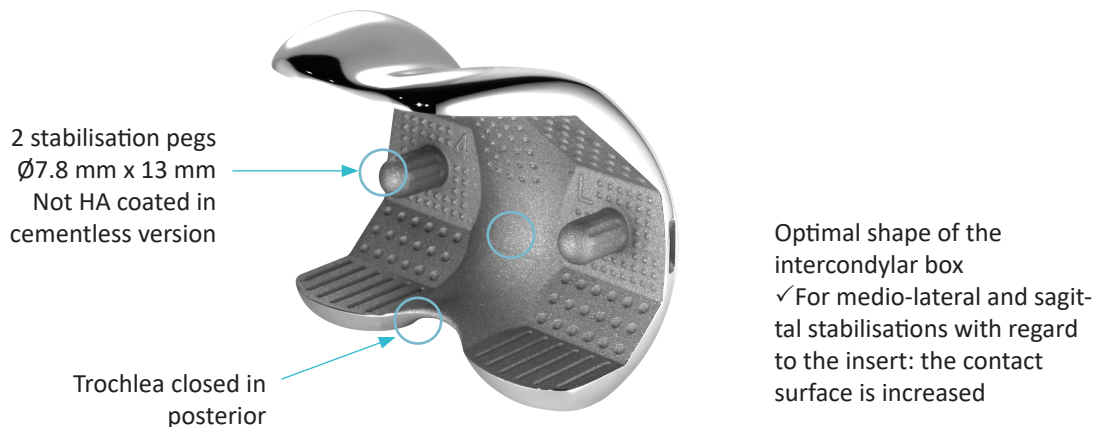

# Patella component

Polyethylene patellar implant available in three versions:

**Onset patellar implant cemented**

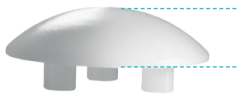

Thickness:  
8 mm

**Inset patellar implant cemented**



Thickness:  
7 mm

# Tibial component

**Tibial insert is mobile in rotation :**

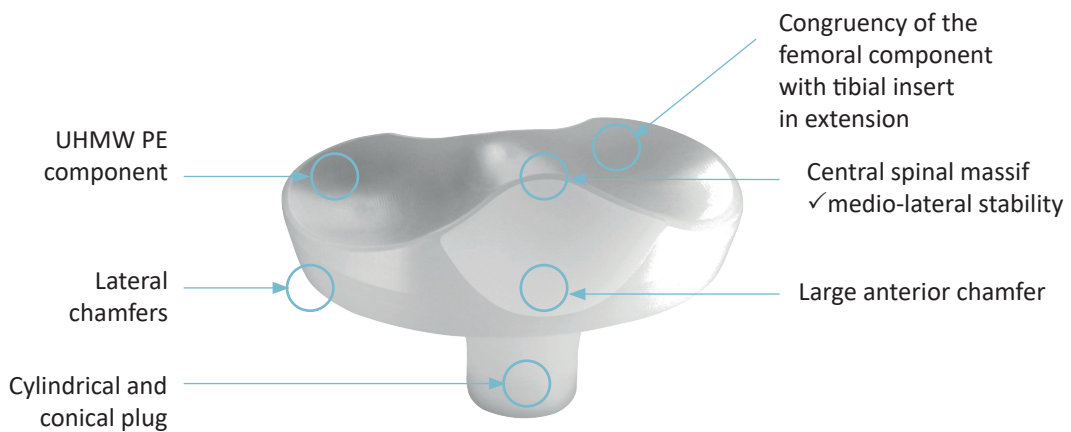

# Tibial component

## Tibial baseplate

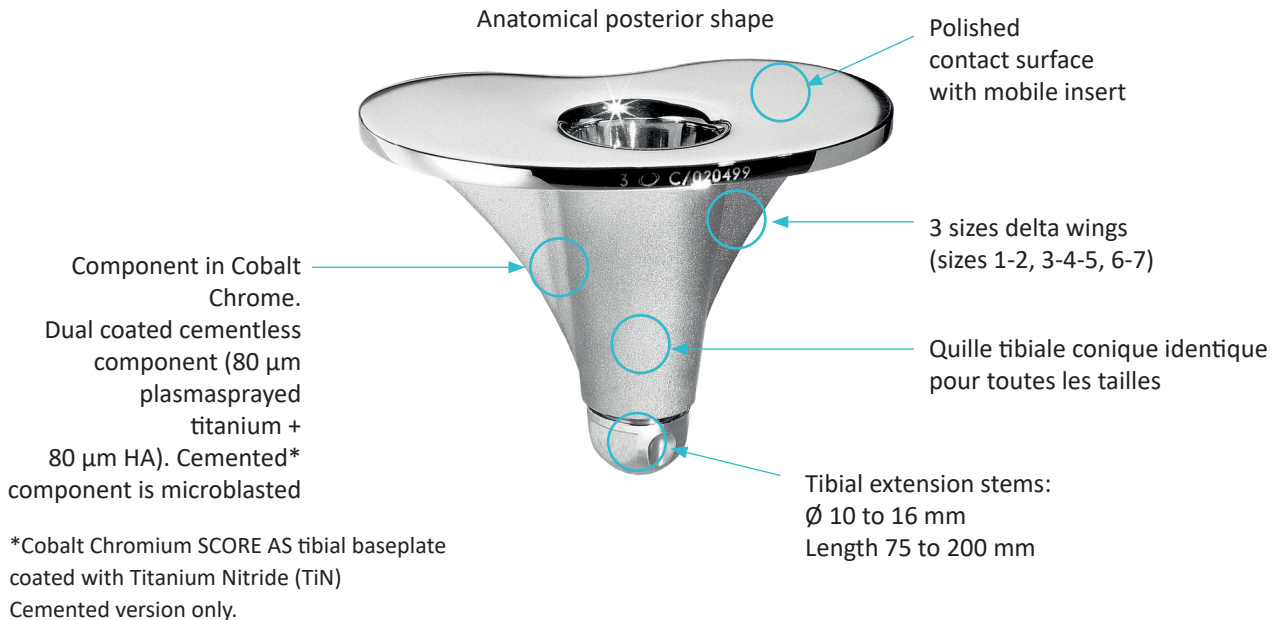

Possibility of using (e.g. in cases of uni revision, or TKA):

	SCORE	SCORE AS	
<p>- Tibial extension stems:</p> <ul style="list-style-type: none"> <li>- Ø 10 to 16 mm</li> <li>- Length 75 to 200 mm</li> </ul>			<p>- Tibial extension stems:</p> <ul style="list-style-type: none"> <li>- Ø10 Lengths 75mm and 100mm</li> <li>- Ø12 Longueur 75 mm</li> </ul>
<p>- Tibial augments:</p> <ul style="list-style-type: none"> <li>- Thickness 5 mm</li> <li>- Thickness 10 mm</li> <li>- Thickness 15 mm</li> </ul>			<p>- Tibial augments:</p> <ul style="list-style-type: none"> <li>- Thickness 5 mm</li> </ul>
<p>- Offset adapters:</p> <ul style="list-style-type: none"> <li>- 2 mm</li> <li>- 4 mm</li> <li>- 6 mm</li> </ul>			

\*The tibial extension stems, the tibial augments, and the offset adapters are intended to be implanted with orthopaedic cement only. SCORE accessories are compatible with the Cemented SCORE baseplate. The AS accessories are compatible with the SCORE AS baseplate.



# Range

## Femoral components:

- Cemented: 7 sizes
- Cementless (only for SCORE): 7 sizes



$\Delta$ AP: increment between sizes: 2.66 mm

$\Delta$ ML: increment between sizes: 3.3 mm

	1	2	3	4	5	6	7
AP	47.1	49.7	52.3	54.9	57.5	60.1	62.6
ML	60	63.3	66.7	70	73.3	76.7	80

## Tibial components:

- Resurfacing patellar implant - cemented:  $\varnothing$  30, 33, 36 and 39 mm
- Inset patellar implant - cemented:  $\varnothing$  23, 26 and 29 mm

## Tibial components:

- Cemented: 7 sizes
- Cementless (only for SCORE): 7 sizes



$\Delta$ AP: 2,3 mm

$\Delta$ ML: 3,5 mm

	1	2	3	4	5	6	7
AP	41.4	43.6	45.9	48.2	50.5	52.8	55
ML	63.5	67	70.5	74	77.5	81	84.5

- Inserts : 7 sizes  
5 thicknesses (10, 12, 14, 16 and 20 mm)

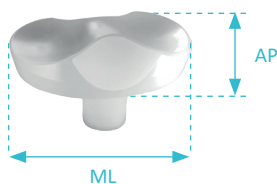

$\Delta$ AP: 2,1 mm

$\Delta$ ML: 3,3 mm

# Component compatibility

Femoral components and inserts sizes

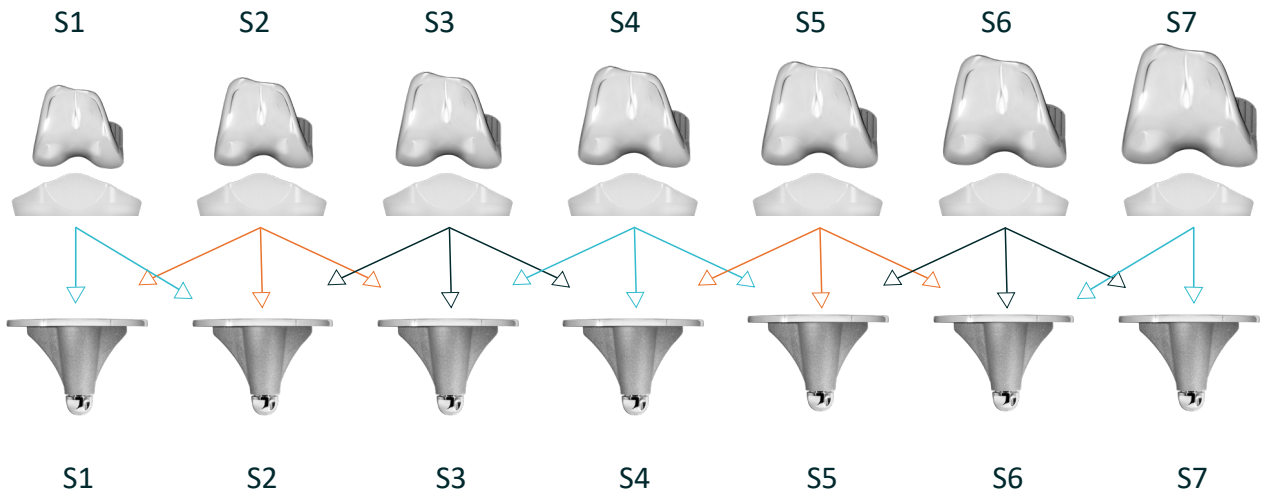

Tibial baseplate



All sizes of Cemented resurfacing patellar implants and Cemented inset patellar implant are compatible with all sizes of SCORE femoral components.

# Surgical Technique overview

1

Distal femoral cut

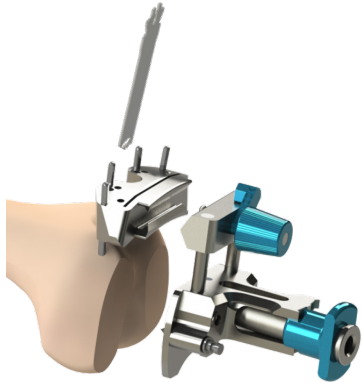

2

Intra-medullary tibial jig



3

Extra-medullary tibial jig



4

Tibial cut

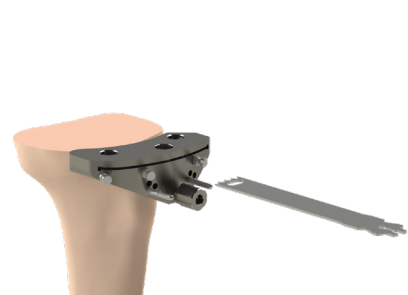

# Surgical Technique overview

5

Extension gap measurement

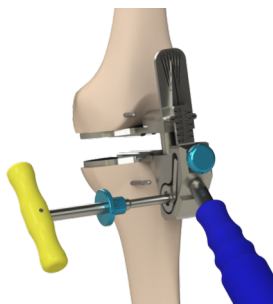

6

Flexion gap transfer

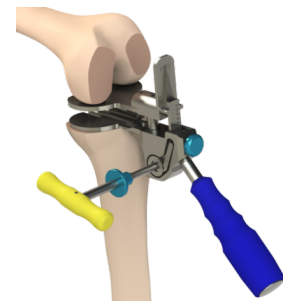

7

Sizing

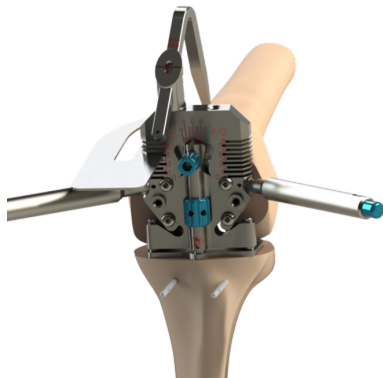

8

Femoral cuts





# Surgical Technique Overview

9

Femoral preparation

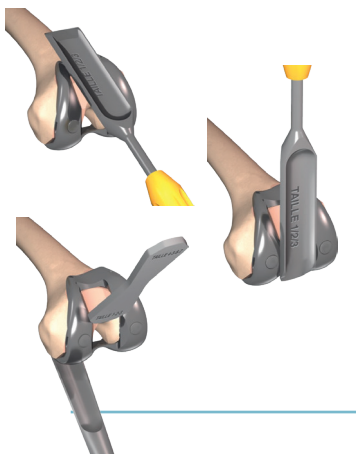

10

Tibial preparation

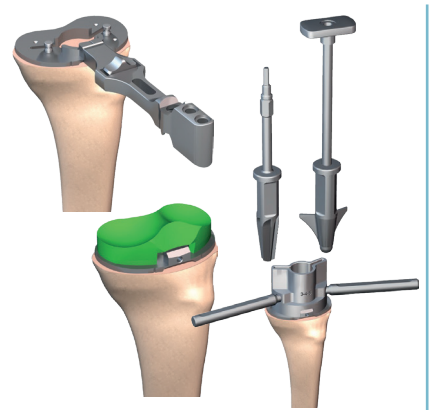

11

Patella preparation  
resurfacing option



12

Patella preparation patellar  
reaming option



---

# 1

# Pre-operative planning

Using X rays and templates, you can determine concerning bone:

## On the tibia:

- The choice between intramedullary and extramedullary aiming.
- The entry point of the intramedullary rod (coronal and sagittal view).
- The adaptation of the tibial stem to the metaphysis (in case of previous tibial osteotomy).
- The osteophytes.
- The severity of the compartment wear.
- The choice of an extension tibial stem, if required.
- The assessment of the baseplate size and the insert thickness.

## On the femur:

- The entry point of the intramedullary rod (front and sideways).
- The anatomical femoral valgus angle.
- The posterior osteophytes.
- The size.

## On the patella:

- The wear of the patellofemoral joint.
- The thickness, the width, the global shape, the tilt and the height of the patella.
- The thickness and the orientation of the patellar resection.
- The mediolateral position of the patellar implant.

### NOTE

The provided templates have a 1:1 scale. Make sure the template scale matches the X-ray scale.

### REMINDER

This surgical technique describes how to use the instrumentation properly. The surgeon is fully responsible for choosing the surgical approach and technique

## 2 Distal femoral resection

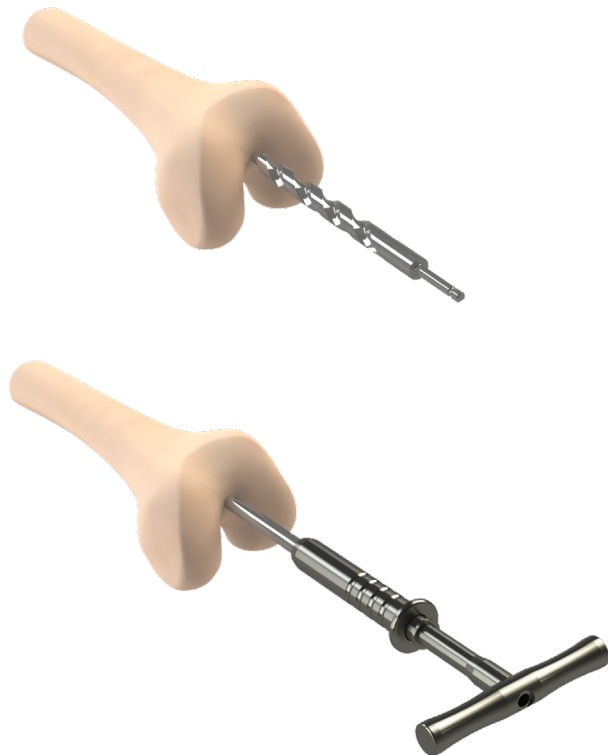

### Intramedullary femoral alignment:

- Bend the knee at 90°
- Remove any peripheral osteophytes.
- Clear out tissues to access the anterior cortex.
- Based on the pre-operative planning, determine the entry point for the intramedullary (IM) canal and open the femoral canal with the Intramedullary Drill Bit.
- Assemble the Intramedullary Rod - Length 400 mm on the T Wrench, and insert it into the canal. The landmark located on the Rod must always be visible.

### NOTE

If the Intramedullary Rod – Length 400 mm cannot be inserted or if there is a pre-existing THA, use the Intramedullary Rod - Length 250 mm.

### Position the femoral valgus alignment guide :

- Adjust the femoral valgus (possible adjustment between 3° and 11° every 2°) to match the femoral valgus measured during the pre-operative planning and place it on the operated leg (LEFT/RIGHT).
- Place the Femoral Valgus Alignment Guide 0° (or 3° or 6°) on the intramedullary rod.
- Make sure the barrel rests against a healthy portion of the distal condyle and confirm the femoral valgus reading.

Femoral Valgus Alignment Guide  
(for right and left sides)

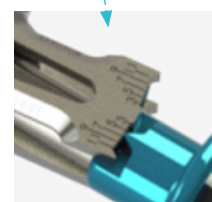
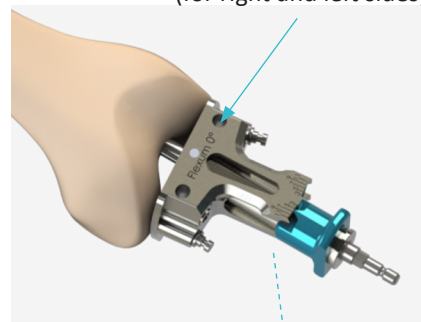

# Distal femoral resection

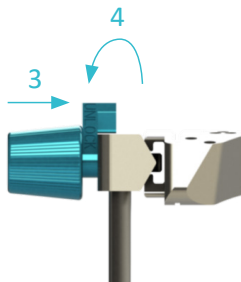
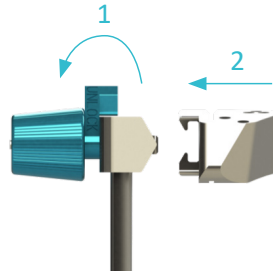

## Assembly of the distal resection guide:

- Assemble the distal resection guide 8 mm (or 10 mm) on the Distal Slide Bar onto the Femoral valgus Alignment Guide 0°.

1- Loosen the wheel on the distal slide bar.

2- Make sure the upper lever is in the « unlock » position, join the distal resection guide and the slide bar together in a « V » by aligning the line on the resection guide with the one on the slide bar, the lines ensure that the two components are centred.

3- Press down on the wheel and 4- turn the upper lever to the « lock » position to lock the two components in place.

## Distal resection guide positioning:

- Place the distal slide bar and distal resection guide onto the valgus alignment guide.
- Adjust the position of the distal resection guide:
  - in the mediolateral direction (to prevent patellar impingement),
  - in the anteroposterior direction (resection guide touches the bone).
- Fully tighten the thumb knob on the distal slide bar to lock the mediolateral position of the resection guide.
- Use the screwdriver H3.5 to secure the valgus alignment guide to the distal slide bar.

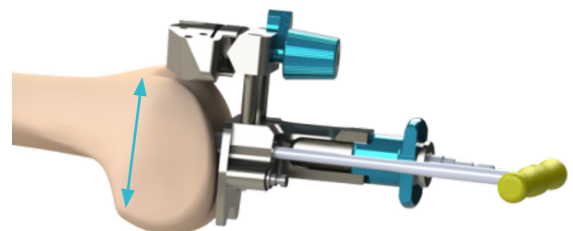
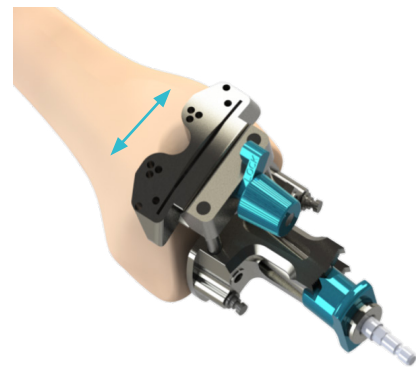

# Distal femoral resection

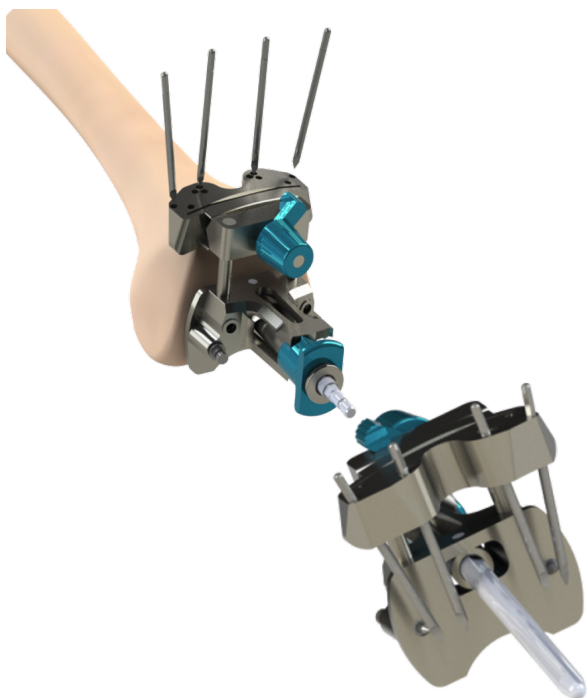

## Pin insertion:

- Use the Universal quick release adaptor for pin or the AO Pin driver assemble on a Surgical Power Reamer to insert two Headless pins length 80 mm into the 0 holes.
- Use two other similar pins inserted in the oblic holes to stabilise the resection guide.

## NOTE

On patients with flexion deformity, the distal cut (initially 8 mm) can be increased by switching the guide in order to have the pins into the +2 or +4 holes.

## NOTE

Depending on the bone quality, Long Drill bit, Ø 3.2, length 145 mm can be used to prepare the holes for the pins.

## Distal cut:

- Remove the intramedullary rod using the T Wrench.
- Loosen the thumb knob on the distal slide bar by moving the upper lever to the « unlock » position and detach the entire distal resection guide.
- Check the cut thickness with the resection gauge.
- Perform the distal cut using a medium AMPLITUDE saw blade.
- Extract the oblic pins with the handpiece or with the pin extractor.
- Slide the resection guide off the pins in the 0 holes, but leave the pins in place in case recutting is necessary.
- If the Tibial resection is achieved first, the Alignment Gauge can be place on the tibial resection to protect the bone.

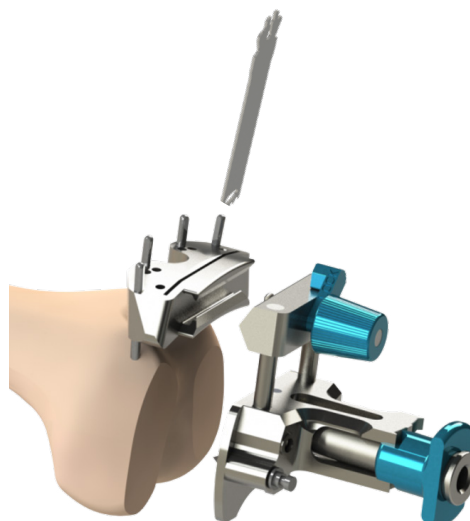

## 3

## Intra-medullary guide (IM)



### Intramedullary tibial alignment :

- Based on the pre-operative planning, determine the entry point for the intramedullary (IM) canal and open the tibial canal with the Intramedullary Drill Bit.
- Assemble the Intramedullary Rod - Length 400 mm on the T Wrench and insert it into the canal, the landmark must always be visible.

### NOTE

If the intra-medullary Rod- Length 400 mm cannot be inserted use the Intra-medullary Rod Length 250 mm.

### Assembly of the Intramedullary System:

- Attach the tibial slide bar and the tibial resection guide (left or right) together onto the tibial bracket. Tighten the Wheel for resection guide and the Wheel for tibial bracket with the H5 Screwdriver or by hand.
- Insert this entire unit onto the intramedullary rod, adjust its rotation relative to the anterior tibial tuberosity and then impact the tabs.
- Clip the tibial stylus onto the resection guide (make sure the clip is fully engaged).
- Set the resection height by using the tibial stylus to palpate either the:
  - healthy side (10 mm cut relative to the chosen point),
  - worn side (0 mm cut relative to the chosen point (exit level of the saw blade).
- For other resection heights, use the 2 mm markings on the tibial slide bar.
- Verify the height of the bone cut with the resection gauge.



### NOTE

You can check the axis using the Alignment gauge assembled with the Universal handle in which the Extramedullary alignment rod slides.

# Extra-medullary guide (EM)



## Assembly of the Extramedullary System and resection height adjustment:

- Attach the tibial slide bar and the tibial resection guide (left or right) together onto the tibial bracket. Tighten the Wheel for resection guide and the Wheel for tibial bracket with the H5 Screwdriver or by hand.
- Assemble the malleolar clamp with the extramedullary alignment guide and with the slide bar.
- Place the malleolar clamp around the ankle, and then place the bracket on the intercondylar eminence.
- Tighten the Wheel for extramedullary Alignment column.
- Set the rotational and sagittal alignments before impacting the tabs.
- Clip the tibial stylus onto the tibial resection guide (make sure the clip is fully engaged).
- Set the resection height by using the stylus to palpate either the:
  - healthy side (10 mm cut relative to the chosen point),
  - worn side (0 mm cut relative to the chosen point (exit level of the saw blade)).
- For other resection heights, use the 2 mm markings on the tibial slide bar.
- Check the bone cut height with the resection gauge.

### NOTE

You can check the axis using the Alignment gauge assembled with the Universal handle in which the Extramedullary alignment rod slides.

## Combined tibial guide



### Landmarks :

- See page 18

### Assembly of the Combined System and resection height adjustment:

- Attach the tibial slide bar and the tibial resection guide (left or right) together onto the bracket. Tighten the Wheel for tibial bracket.
- Assemble the malleolar clamp with the extramedullary alignment guide and with the tibial slide bar.
- Place the malleolar clamp around the ankle and then place the tibial bracket onto the intercondylar eminence.
- Set the rotational and sagittal alignments before impacting the tabs.
- Clip the tibial stylus onto the resection guide (make sure the clip is fully engaged).
- Set the resection height by using the stylus to palpate either the:
  - healthy side (10 mm cut relative to the chosen point),
  - worn side (0 mm cut relative to the chosen point (exit level of the saw blade)).
- For other resection heights, use the 2 mm markings on the tibial slide bar.
- Check the bone cut height with the resection gauge.

### NOTE

You can check the axis using the Alignment gauge assembled with the Universal handle in which the Extramedullary alignment rod slides.



## 5 Tibial resection

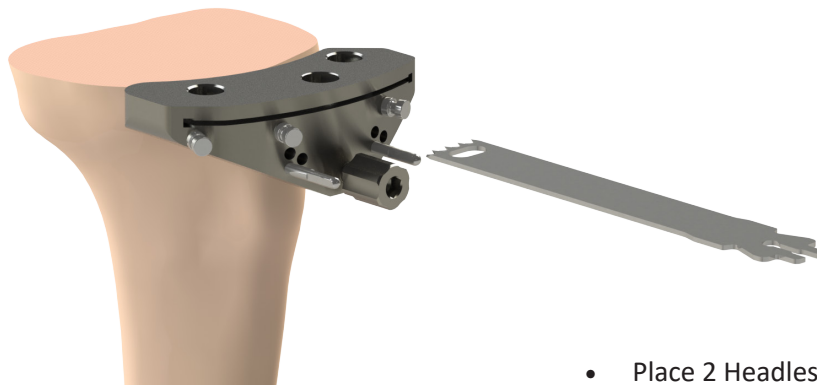

### NOTE

Depending on the bone quality, long Drill bit, Ø 3.2, length 145 mm can be used to prepare the holes for the pins.

- Place 2 Headless pin length 80 mm in the 0 mm holes (with the universal or AO snap-in connector).
- The +2 and +4 markers will be used if a tibial recut is required.
- Place the « T » end of the slaphammer into the opening on the tibial bracket and then remove the entire intra- or extramedullary assembly.
- Place the resection guide flush with the anterior tibial cortex.
- Insert 3 Headed pin length 70 mm (or the Collared Threaded Pin Ø3.2-L57, to stabilize the resection guide.
- Perform the tibial cut.
- Remove the headed pins with the pin extractor.
- Slide the resection guide off the pins, by leaving the pins in place in case a recut was necessary (the +2 and +4 holes will be used at that time).
- The flat rasp can be used to flatten the tibial resection.

## 6

# Extension and flexion gaps

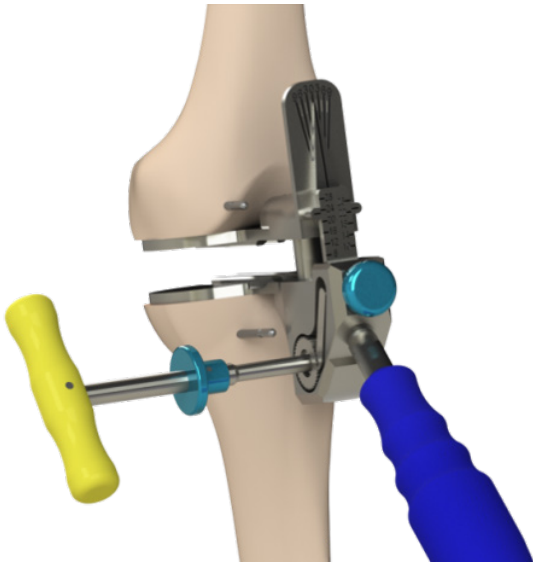

## Extension gap measurement:

This step is carried out after performing the distal femoral and tibial cuts. The goal is to achieve a rectangular gap in extension when the ligaments are under tension. The resulting gap will be measured and should be the same when the knee flexed.

- Insert the Extra-articular Ligament Balancer V2 into the knee joint with the knee extended.
- Insert the Snap Screwdriver H5 into the balancer's cog wheel.
- Turn the Snap Screwdriver H5 to operate the distraction mechanism and apply the desired amount of tension. Do not apply excessive distraction, otherwise the knee will flex. The knee must stay extended during the measurements.
- Make sure the tibial and distal femoral cuts are parallel, and check the height of the tibiofemoral gap.
- If the tibiofemoral gap is less than the 18 mm minimum gap needed (10 mm for the tibial component plus 8 mm for the femoral component), redo the tibial or distal femoral cut.

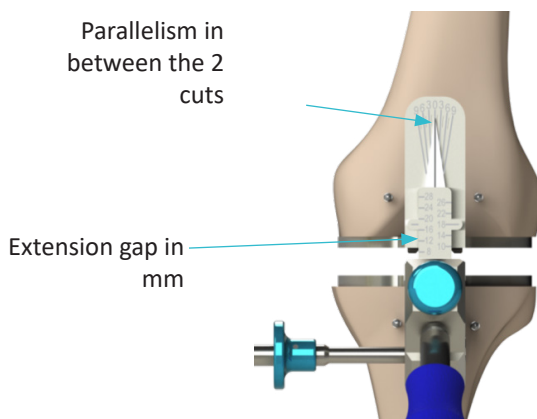

Minimum gap in extension :

18 mm = 10 mm (tibial component) + 8 mm (femoral component)

### NOTE

Ligament can be released to achieve desired ligament balance (value of 0 on Balancer).

# Extension and flexion gaps

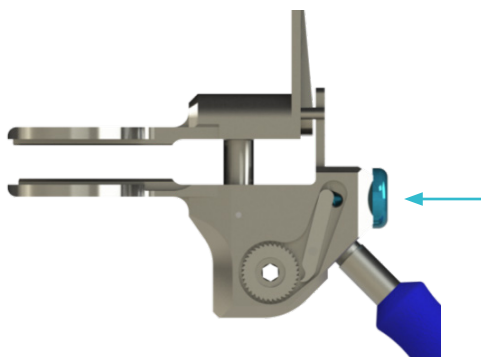

- Press the blue unlock button to remove the Ligament balancer from the joint.

**NOTE**

Remove the 2 Headless pin length 80 mm left in anterior part.

## Flexion gap measurement:

- Flex the knee.
- Insert the balancer and apply the desired tension (same procedure as with knee extended).
- Read the flexion gap value and femur rotation value (induced by ligament laxity) relative to the tibia.
- Make sure the flexion gap is equal to the extension gap (8 mm must be subtracted from the extension gap value).

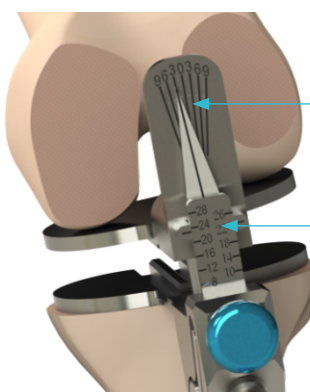

Femoral rotation in degree

Read flexion gap here (subtract 8 mm from extension gap)

## Spacer technique:

- Spacers can be used to check the ligament balancing.
- In extension: assemble the Spacer Thickness 18 mm on the Universal handle. Apply a slight varus and valgus forced to check the balance. If it's too loose, it is possible to add a Spacer Thickness 2 mm for Spacer or a Spacer Thickness 4 mm for Spacer.
- In Flexion: assemble the Spacer Thickness 10

mm (or a Spacer Thickness 7 mm if the joint is too tightened) on the Universal handle. Apply a slight varus and valgus forced to check the balance. If it's too loose, it is possible to add a Spacer Thickness 2 mm for Spacer or a Spacer Thickness 4 mm for Spacer.

- Make sure the flexion gap is equal to the extension gap (8 mm must be subtracted from the extension gap value).

# Extension and flexion gaps

## Transfer of gap into flexion:

- On the 4-in-1 Pin Positioner, set the femoral rotation based on the measurement taken with the Ligament Balancer.
- If the flexion gap is equal to the extension gap, set the posterior plate position to 0 mm.
- If the flexion gap is larger than the extension gap, set the posterior plate position to -2 mm to reduce the posterior gap by 2 mm.
- If the flexion gap is smaller than the extension gap, set the posterior plate position to +2 mm to increase the posterior gap by 2 mm.
- Insert the 4-in-1 probe.

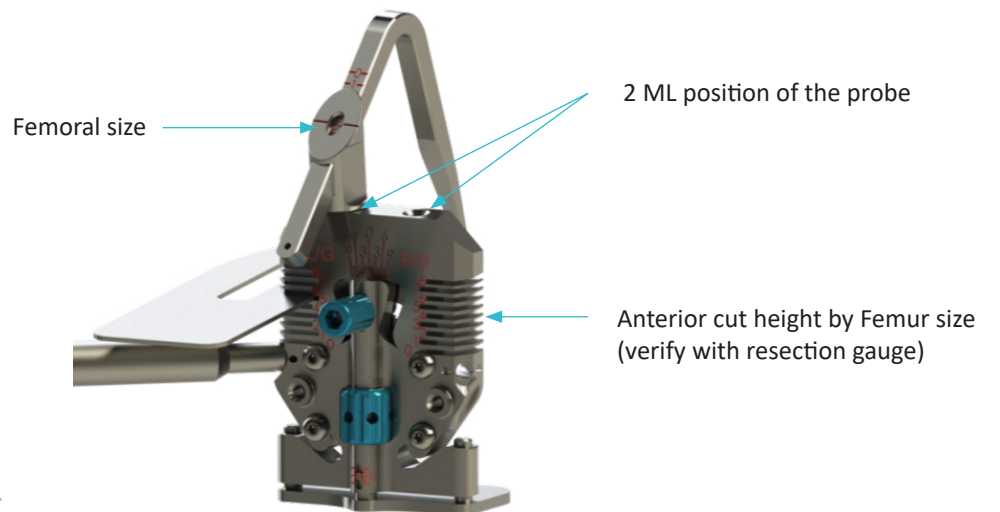

### NOTE

The Pin Positioner uses a posterior reference.

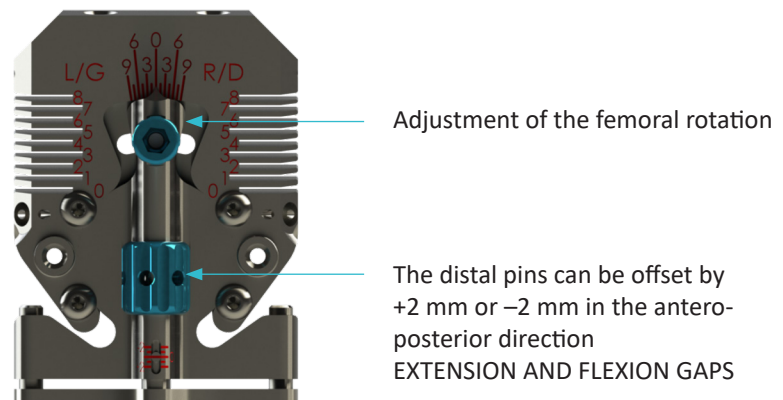

## 7 Femoral resections

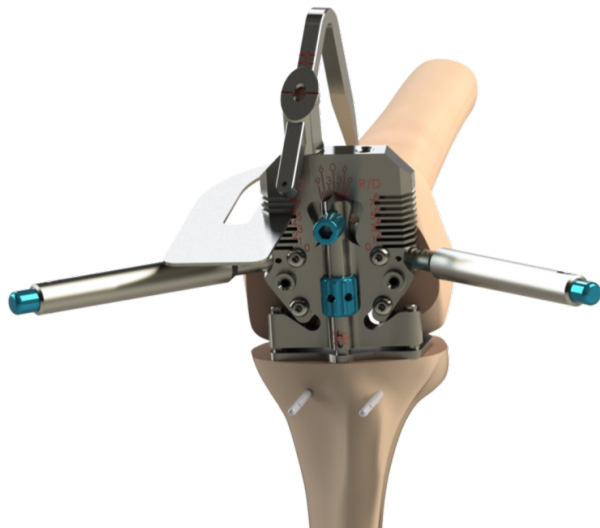

### Distal pin insertion :

- Remove the Ligament Balancer and place the 4-in-1 Pin Positioner while making sure:
  - it is flush with the distal cut and
  - it rests against the posterior condyles
- Place the 4-in-1 probe tip against the anterior cortex and determine the femoral component size.
- Verify the size by placing the resection gauge into the slots to preview the anterior cut position.
- It is possible to insert an Alignment Pin  $\emptyset$  2 Length 150 mm\* on each side of the Pin Positioner in order to check the femoral rotation.
- If the femoral size shown is between 2 sizes, the distal pins can be offset:
  - **position + 2 mm**: femoral component position will be offset by 2 mm anteriorly (posterior gap is 2 mm larger, anterior cut is 2 mm higher)
  - **position - 2 mm**: femoral component position will be offset by 2 mm posteriorly (posterior gap is 2 mm smaller, anterior cut is 2 mm lower)
- Insert the two Headless Pin,  $\emptyset$ 3.2 length 65 mm.
- Remove the 4-in-1 pin positioner.

# Femoral resections



## Femoral cuts:

- Set the 4-in-1 Femoral resection guide that corresponds to the measured size on the distal pins in the central holes (neutral position).
- Make sure side of the resection guide is flush with the distal cut.
- Use the resection gauge to check the anterior cut will not notch the femoral cortex is intact.
- If the femoral cuts need to be adjusted in the anteroposterior direction, set the 4-in-1 resection guide on the distal pins in either the lower holes (flexion gap increased by +1mm) or the upper holes (flexion gap decreased by -1 mm).

- Secure the resection guide with Headless pin length 80 mm or with Collared Threaded Pin  $\varnothing 3.2$ -L57.
- In patients with osteoporosis, better fixation can be achieved by adding a pin in the intercondylar notch, connect the two removable handles on the cutting guide for better hold while inserting the pins.
- Make the anterior and posterior cuts using a medium AMPLITUDE saw blade that matches the instrumentation set and motorized handpiece.
- Remove the distal pins using the pin extractor.
- Make the 2 chamfer cuts.

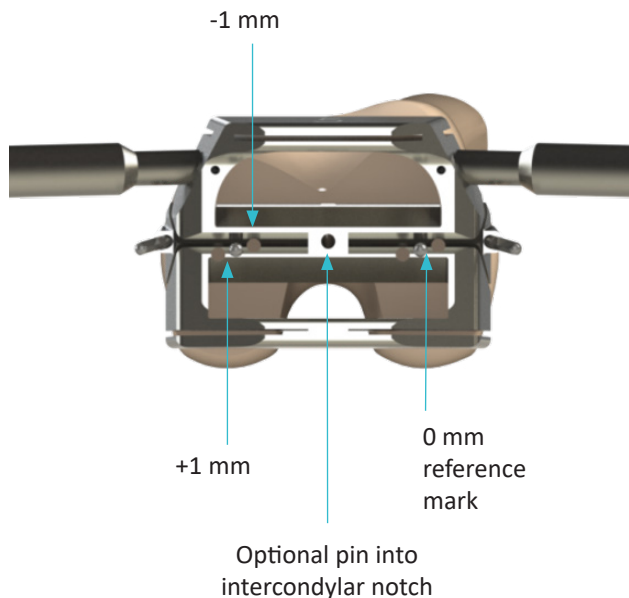

## 8 Femoral preparation

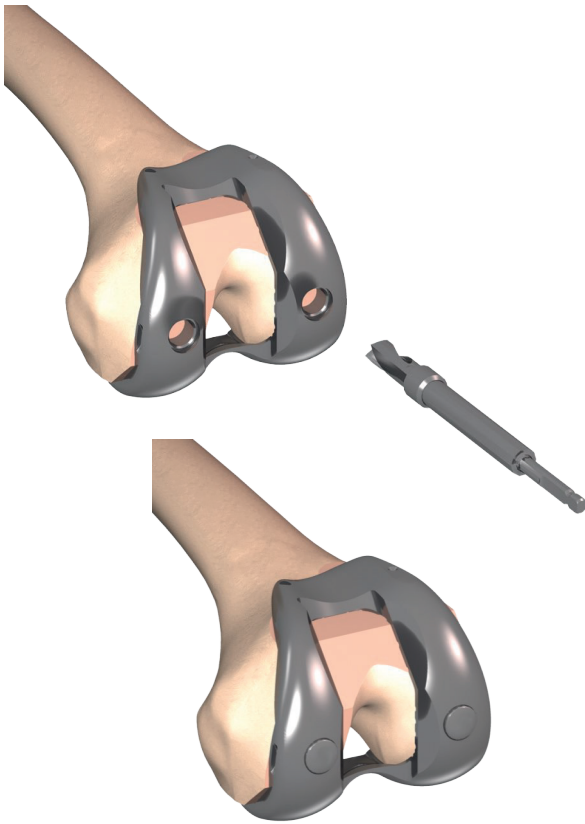

### Mediolateral femoral adjustment :

- Impact the SCORE Femoral Trial component (corresponding to the operated side and to the size of the Femoral Resection Guide) using the Femoral Condyle Holder (trial position), by choosing a mediolateral position.
- Finish impacting the Trial Component using the Femoral Component Impactor.
- Drill the first hole with the Drill for peg holes and insert the Trial peg for trial femoral component.
- Drill the second hole and insert the second Trial peg for trial femoral component.

### Trochlear groove preparation :

- Prepare the intercondylar notch using the cutting end of the Femoral Rasp that corresponds to the size of the selected femoral component (size 1/2/3 or size 4/5/6/7).
- The rasp is constrained on two sides. Finalise the preparation with the roughened end.
- Use the Intercondylar Control Gauge to ensure the intercondylar notch has been prepared correctly.
- Resect any posterior osteophytes with the Cutting Gauge.

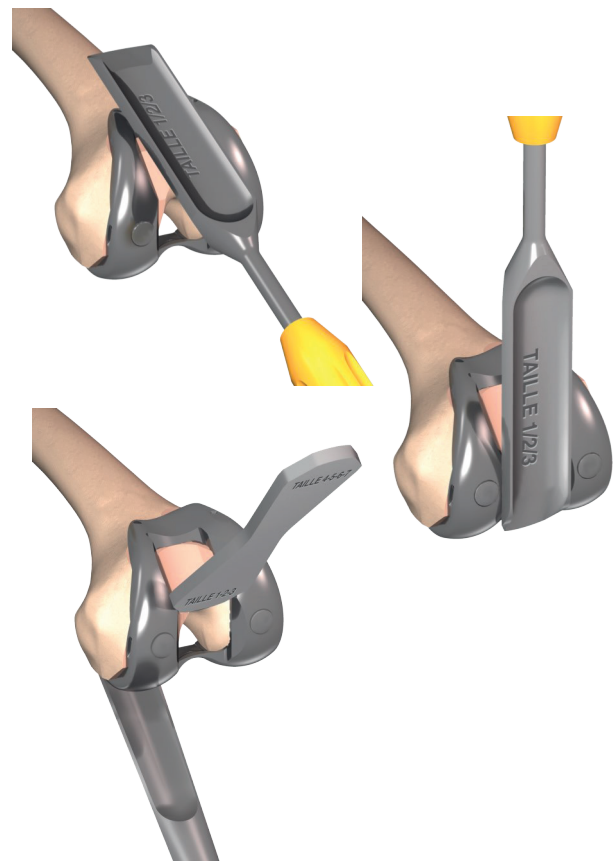

## 9 Tibial preparation

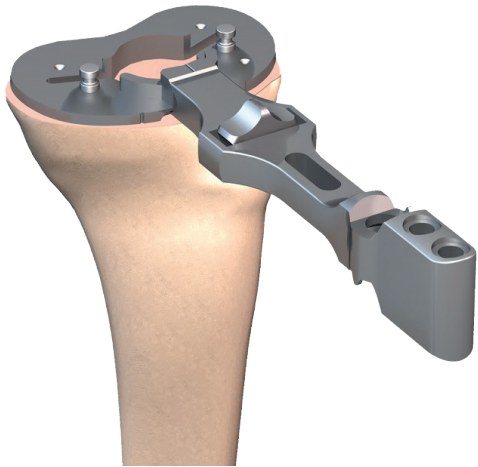

### Trial baseplate positioning:

- Determine the size of the Trial Tibial Baseplate. The baseplate can be one size larger or smaller than the size of the femoral component.
- Position the Trial Tibial Baseplate onto the tibial cut.
- Fix the baseplate with two Headed Pins length 30 mm.

### NOTE

Depending on the bone quality a Long Drill bit,  $\varnothing$  3.2, length 145 mm can be used to make the holes for the pins.

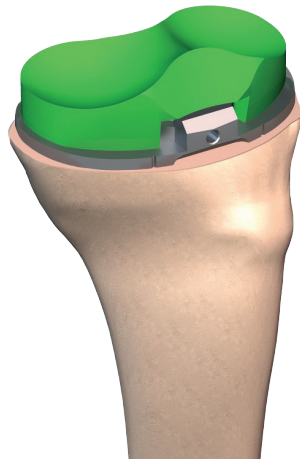

### Trials:

- Position the mobile Trial Insert of a size corresponding to the femur starting by Thickness 10mm.

### NOTE

The insert size must always be identical to the femoral size.

### Preparation:

- Remove the 2 headless pins in the tibia.
- Tighten the Standard Trial Stem on the Punch Guide for Tibial Baseplate with the Tibial Stem Wrench.
- Position the appropriate size of the Punch guide for tibial baseplate (1/2 or 3/4/5 or 6/7) onto the Trial Tibial Baseplate. If needed Two Removable Handles for Punch Guide can be screwed on the Pun Guide to strongly maintain it.
- Ream using the Reamer for tibial extension stem until the stop (same for all sizes).
- Impact the appropriate sized Punch for Tibial Extension Stem (1/2 or 3/4/5 or 6/7), in case of a sclerotic bone or after osteotomy, prepare first with an osteotome.

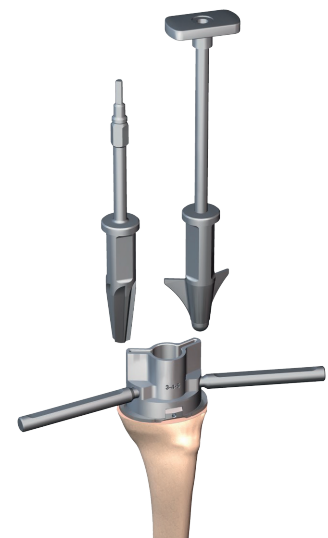

### NOTE

Check the integrity of the 2 instruments (Punch and trial stem) after extraction of the assembly.



## 10 Patella preparation: patellar resection option



### Patellar preparation:

- Clear osteophytes

### Position the patellar resection guide:

- Place the Patellar resection clamp so the two lugs are on the anterior side of the patella.
- With the clamp jaws open, bring the Patellar resection Gauge in contact with the articular surface using the adjustment knob.
- Lock the clamp.
- Evaluate remaining bone.
- Push the saw blade into the slot to perform the cut.

### Patellar preparation:

- Use the Patellar Drilling Guide  $\varnothing 30$ ,  $\varnothing 33$  or  $\varnothing 36$  to determine the size of patellar component needed: 30, 33 or 36 mm.
- Centre and impact the drilling guide.
- Make the 3 holes for the pegs with the Drill bit for resurfacing patella.
- Place the Trial resurfacing patella of the same diameter using the Clamp for Locking Ring.
- Test the articulation in the trochlea.

### Patellar implantation:

- Clean and dry the bone surface.
- Apply cement onto the implant and the patellar cut.
- Position the implant on the cut.
- Tighten the implant using the Patellar Impaction clamp.
- Remove the excess of cement.
- Keep the clamp until the cement is dry.

### NOTE

The thickness of the patella implant is 8mm for all the diameters and it is advisable to leave a rem-nant of 12mm of residual bone.

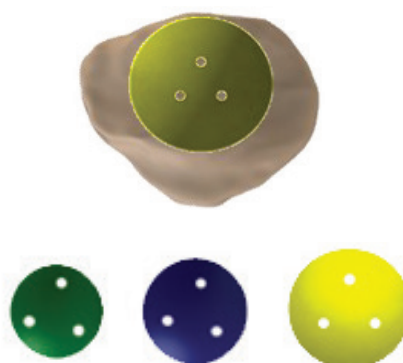

# 11 Patella preparation : patellar reaming option



## Patellar preparation:

- Clear osteophytes.

## Position the Patellar reaming forceps:

- Centre the Trial inset patellar - cemented  $\varnothing$  23 mm – Plastic (or  $\varnothing$  26, or  $\varnothing$  29) on the articular surface of the native patella.
- The appropriate size ( $\varnothing$  23, 26 or 29 mm) is determined based on the following criteria:
  - Superior-to-inferior length of the articular surface
  - Width of the patella's medial articular facet
- The size must be slightly smaller (by about 2 mm) than the superior-to-inferior length of the articular surface and must be slightly inside the medial edge of the medial articular facet
- Assemble the Patella Reamer Surfacing Guides corresponding to the chosen patellar implant size onto the Patellar reamer Clamp and lock it.
- Position the clamp. The inferior jaw on the Patellar reamer Clamp must rest against the anterior side of the patella. The clamp must rest against at least one of the patella's two articular facets.
- Use the thumb knob to tighten the Patellar reamer Clamp .
- Assemble the reamer for inset patella of the same size as the chosen clamp onto the power tool.
- Ream the patella until the stop is reached.

## Trials:

- Assemble the Patellar Reamer Impaction Clamp onto the Patellar reamer Clamp and lock it.
- Use it to place the Trial inset patellar - cemented of the selected size into the native patella.
- Test the patella tracking.

## Patellar implantation:

- Clean and dry the bone surface.
- Use the Patellar Reamer Impaction Clamp assemble on the Patellar reamer Clamp to insert the chosen patellar component.

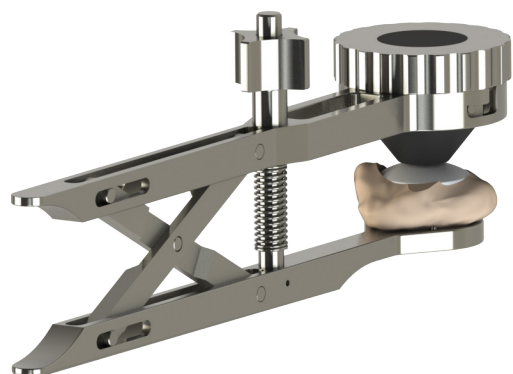

## 12 Definitive implants



### Insertion of chosen tibial baseplate:

- On the selected tibial baseplate (with or without cement), tighten the stem or, if required, the extension stem using the Tibial Stem Wrench.
- Wash and dry bone surfaces and the joint space.
- For the cemented version, apply a layer of cement to the bone, the implant surface or to both.
- Position the tibial baseplate and impact it using the Baseplate impactor.
- For the cemented version, remove any excess cement taking care to limit the movement of the components while the cement is curing.

### Insertion of chosen insert:

- Place the polyethylene insert with the size corresponding to the femur and the thickness validated during testing.

### Insertion of chosen femoral component:

- Assemble the femoral implant (with or without cement) of the selected size on the Femoral condyle Holder (anterior position).
- If a cemented femoral implant is used, it is recommended to apply little cement on the posterior condyles and no cement on the posterior area of the notch, due to the implant design.
- Place the femoral component onto the femoral cuts, make sure it is aligned precisely, and then impact it so that the Femoral condyle holder can be removed.
- Finish impacting the component using the Femoral component impactor.
- For the cemented version, remove any excess cement taking care to limit the movement of the components while the cement is curing.

# Option: Tibial augment, tibial extension stem and offset adapter

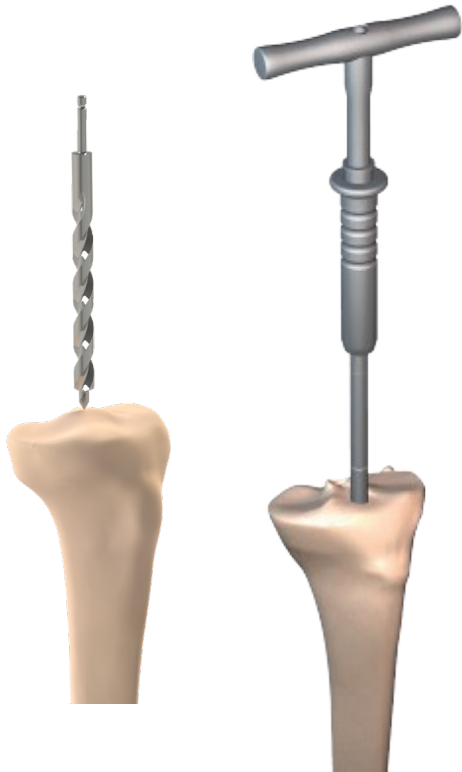

## Intramedullary tibial aiming:

- Based on the pre-operative planning, determine the entry point for the intramedullary (IM) canal and open the tibial canal with the Intramedullary Drill Bit.
- Gradually ream the medullary canal using the Reamers (Ø10, 12, 14,16) mounted on the T-Wrench.
- The graduated reamers are used to estimate the most appropriate extension stem length.
- Use progressively larger Reamers until contact is made with the bone cortex.
- Leave the last reamer used in place.

## NOTE

If combined aiming is preferred, assemble the malleolar clamp with the extramedullary alignment rod and attach it around the ankle.

Set the rotation of the extramedullary alignment guide and its position in the sagittal plane before locking it into place with the H5 screwdriver

## Tibial instrumentation positioning:

- Assemble the Tibial slide bar and the Revision Tibial Resection Guide onto the Revision Tibial Bracket. Tighten the Wheel for Resection Guide.
- Put the entire unit onto the Reamer or Intramedullary Rod length 400 mm (or 250 mm) left in the tibia.
- Set the resection height with the stylus as follows:
  - On the healthy side: stylus positioned at 10 mm (10 mm cut relative to this reference).
  - On the worn side: stylus positioned at 0 mm (exit level of saw blade).
  - For other resection heights, use the 2 mm markings on the alignment rod.
  - Determine if a tibial augment is needed (resection guide place in the half-slots labelled 5/10/15).



# Option: Tibial augment, tibial extension stem and offset adapter

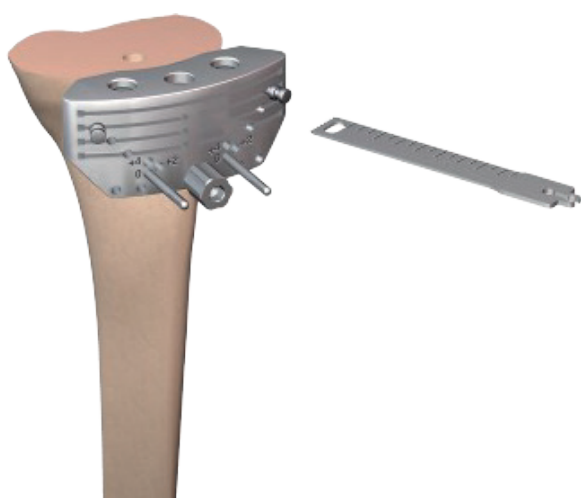

## Tibial cut:

- Use the Universal quick release adaptor for pin or AO Pin Driver on a power engine to insert 2 Headless pin length 80 mm into the 0 landmarks of the Revision Tibial Resection Guide.
- Loosen the screw on the Revision Tibial Bracket with the H5 screwdriver.
- Use the slaphammer to remove the intramedullary (and extramedullary) alignment rod.
- Set the resection guide against the bone.
- Stabilize the Revision Tibial Resection Guide with 3 Headed pin length 70 mm; the pin holes can be predrilled with the Long Drill bit,  $\varnothing$  3.2, length 145 mm.
- Perform the medial and lateral tibial resection(s).
- Remove the headed pins with the pin extractor.
- Slide the resection guide off the pins, but make sure the pins stay in place in case recutting is required; if so, the +2 and +4 marks will be used.
- Make the cut, then assess the gaps and ligament tension with the knee flexed (Spacer Thickness 10mm) and extended (Spacer Thickness 18mm (see page 23)).

### NOTE

Headless Pins have to be positioned closed to the main resection slot. In case of a resection for a augments, choose the holes just below for the Headless Pins

### NOTE

Use a medium saw blade (AMPLITUDE) to make the tibial cuts and those of the tibial augments (slots at 5/10/15 mm) if needed

---

# Option: Tibial augment, tibial extension stem and offset adapter

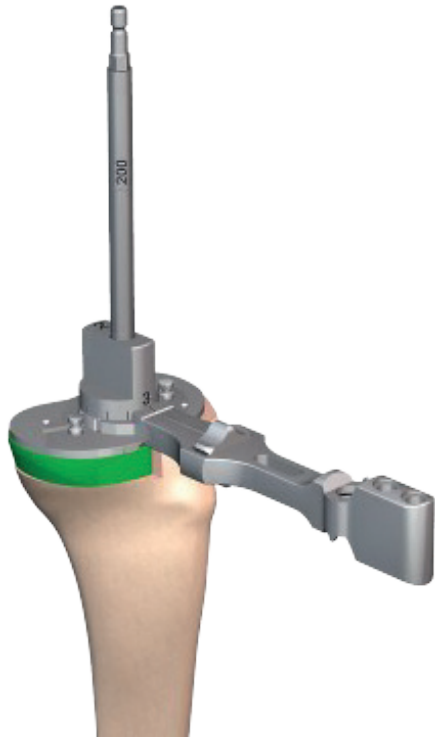

## Positioning of the trial Baseplate:

- Remove the two Headless pins that were left in the tibia (after the tibial cut is completed).
- Select the trial tibial baseplate that provides the best possible bone coverage.
- Reposition the Reamer selected during the tibial resection onto the T Wrench.
- Assemble the Offset Positioner for Trial Tibial Baseplate - 0 mm - onto the trial tibial baseplate.
- Insert these two components onto the reamer and on the tibial cut.
- If needed, a Trial Tibial Half-Wedge - Size 1/2 (or 3/4/5 or 6/7) thickness 5 mm or a Trial tibial half-wedge - Size 1/2 (or 3/4/5 or 6/7) thickness 10 mm (or 15mm) LAT.R./MED.L (or MED.R / LAT.L) of the same size of the baseplate can be placed between the Trial Tibial Baseplate and the resection done for the Augment.

- If the trial baseplate does not fully cover the tibial cut surface when it is centred on the reamer, use the 2, 4 or 6 mm Offset Positioner for Trial Tibial Baseplate instead.
- Turn the offset positioner until the trial tibial baseplate covers the cut surface completely.
- Make note of the adapter size and its position using the graduations on the adapter and the mark on the trial baseplate. This information will be used when the trial and final components are assembled.
- Secure the unit with 2 headed pins; the appropriate pin length 30, 50 or 70 mm depends on the thickness of any tibial augment that is used.
- Remove the reamer and offset positioner.
- Finalise the tibial preparation (see page 28).

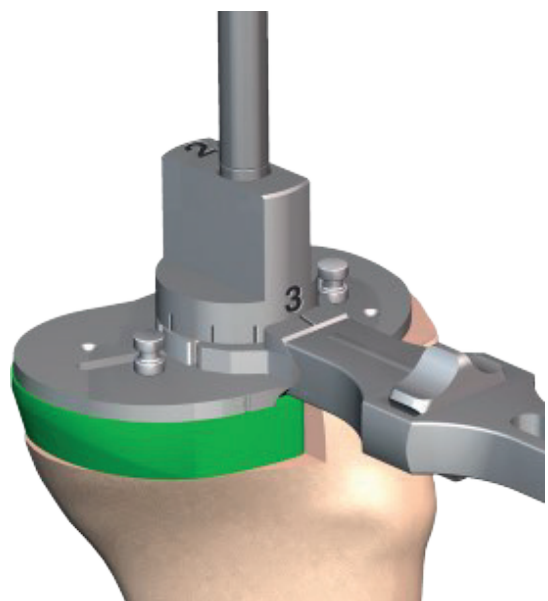

# Option: Tibial augment, tibial extension stem and offset adapter



## Tibial trials:

- Screw the Trial Extension Stem (length and diameter correspond to final reamer used) to the Trial Offset Connector corresponding to the selected tibial offset positioner. These components are assembled using the Wrench for Offset Connector and Tibial Stem Wrench.
- With the H5 screwdriver, tightly screw this unit to the Delta Wing for Tibial Trials while making sure the position of the Trial Offset Connector previously determined from the trial tibial baseplate is maintained.
- Impact the delta wing/connector (if used)/ extension stem unit through the tibial baseplate into the tibia until it stops.
- Secure the entire unit to the trial baseplate using the Thumb Knob to Connect Baseplate / Delta Wing. Tests can now be carried out in the same configuration as the final implants.

### NOTE

If no adapter is used, screw the trial extension stem directly into the delta wing for tibial trials.

Length	Diameters			
75	10	12	14	
100	10	12	14	16
150	10	12	14	16
200		12	14	

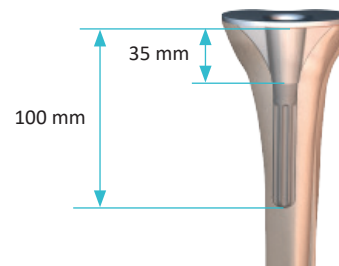
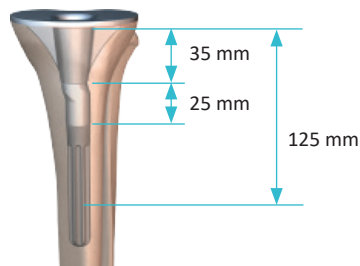

Examples with 100mm long extension stem



---

# Option: tibial augment, tibial extension stem and offset adapter

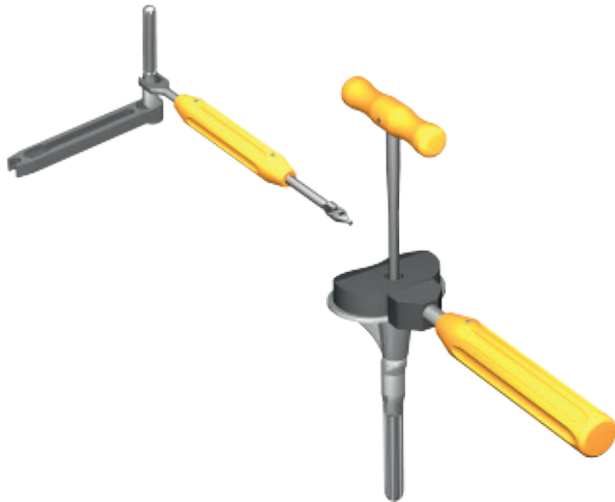

## Assembly of definitive tibial implants:

- Screw the tibial extension stem to the offset adapter that corresponds to the validated tibial offset positioner. These components are assembled using the Wrench for Offset Connector, extension stem wrench and the H5 Screwdriver. If no offset adapter is used, screw the extension stem directly into the tibial baseplate using the Tibial Stem Wrench and the H5 Screwdriver .
- Impact the whole unit into the tibial baseplate while matching the position determined during tibial preparation (laser markings can be found on the edge of the delta wing).
- Place the Tibial Impactor with Offset Connector into the female side of the baseplate taper.
- Finish impacting by firmly tightening the screw in the Tibial Impactor with Offset Connector with the H5 screwdriver.
- In case of modification of the adjustment of the Offset adapter; the whole assembly can be disassembly with the Extractor for Offset Connector. Change the adjustment of the assembly and tighten the assembly.

## Placement of tibial implants:

- Carefully lavage the implantation site to clean it out.
- Prepare the bone cement and apply it to the tibial cut surface or under the tibial baseplate.
- If using a tibial augment, apply a thin layer of cement between the augment and tibial baseplate.
- Impact the final components into the tibia using the trial baseplate impactor and make sure the augment is perfectly positioned relative to the tibial baseplate and tibial cut.
- Tighten the tibial impactor with offset connector one last time before removing it completely
- Remove any excess cement.
- Place a tibial insert of the size corresponding to the femur and thickness validated during the trials.



# Instrumentation

**The SCORE / SCORE AS conventional instrumentation\* consists of 6 trays:**

- Instrumentation set for SCORE Common set
- Instrumentation set for SCORE Resection tibial set
- Instrumentation set for SCORE Tibia trials set
- Instrumentation set for SCORE 4 in 1 with pin positioner
- Instrumentation set for SCORE Trial femoral set

**And either of:**

- Instrumentation set for SCORE Primary - patella resection set (conventional)
- Instrumentation set for SCORE Patella set - remaining patella set

**In addition:**

- Instrumentation set for SCORE Tibial revision
- Sterile large saw blades
- Sterile medium saw blades

\* Not all devices presented in this Surgical Technique may be registered in your country. Please contact your Amplitude Sales Representative for availability.

# Instrumentation

Score: Common set

2-02999130

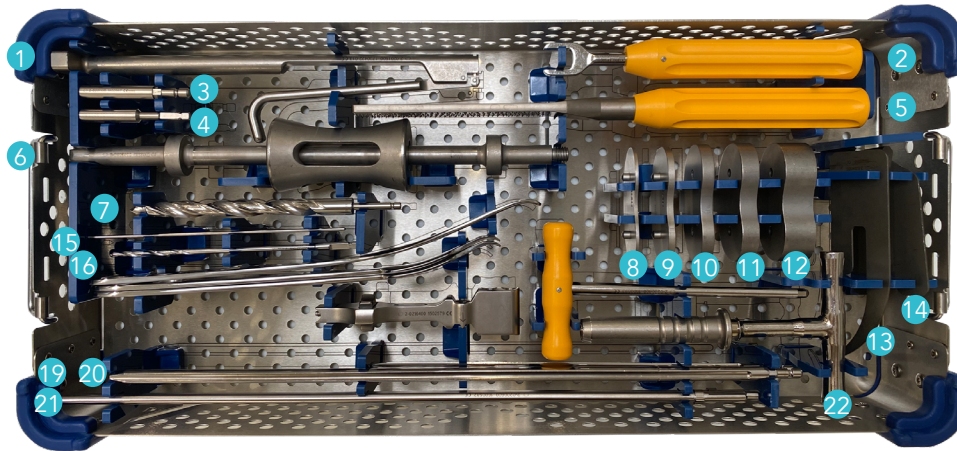

Item	Name	Product No.	Qty
1	Pin extractor	2-0201500	1
2	Tibial Stem Wrench	2-0205500	1
3	Universal quick release adaptor for pin	2-0201100	1
4	Pin Driver AO	2-0201200	1
5	Flat Rasp	2-0206800	1
6	Slaphammer	2-0206900	1
7	Intramedullary Drill Bit	2-0200100	1
8	Spacer thickness 2 mm for spacer	2-0207002	1
9	Spacer thickness 4 mm for spacer	2-0207004	1
10	Spacer Thickness 7 mm	2-0200707	1
11	Spacer Thickness 10 mm	2-0200710	1
12	Spacer Thickness 18 mm	2-0200718	1
13	Resection Gauge	2-0204500	1
14	Alignment Gauge	2-0206300	1
15	Alignment Pin Ø 2 Length 150 mm	2-0103000	2
16	Long Drill bit, Ø 3.2, length 145 mm	2-0102400	1
19	Intramedullary Rod length 250 mm	2-0200200	1
20	Intramedullary Rod length 400 mm	2-0200300	1
21	Extramedullary Alignment Rod	2-0200600	1
22	T Wrench	2-0200400	1
23	Extramedullary Alignment Rod	2-0200600	2
24	T Wrench	2-0200400	1

# Instrumentation

## Score: Resection tibial set

2-0299982

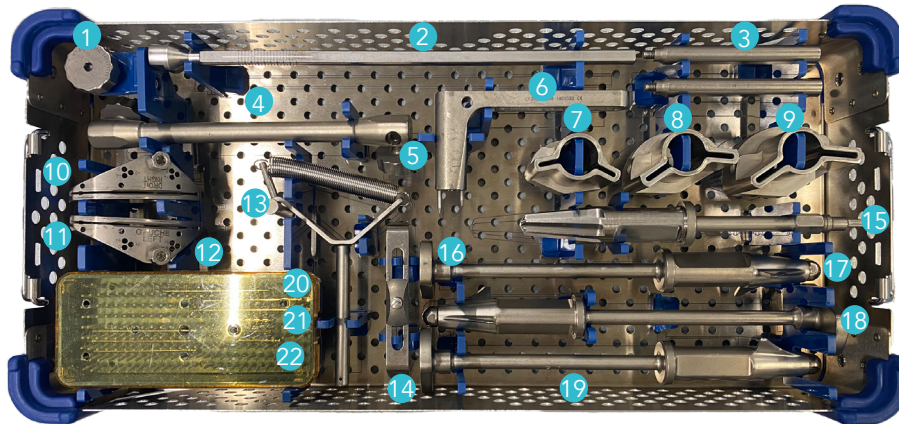

Item	Name	Product No.	Qty
1	Wheel for tibial bracket	2-0202100	1
2	Tibial slide bar	2-0201900	1
3	Removable handle for punch guide	2-0206200	2
4	Extramedullary alignment guide	2-0201700	1
5	Wheel for extramedullary Alignment column	2-0201800	2
6	Tibial bracket	2-0202000	1
7	Punch guide for tibial baseplate size 1/2	2-0202612	1
8	Punch guide for tibial baseplate size 3/4/5	2-0202635	1
9	Punch guide for tibial baseplate size 6/7	2-0202667	1
10	Tibial resection guide Left	2-0202300	1
11	Tibial resection guide Right	2-0202200	1
12	Wheel for resection guide	2-0203800	2
13	Malleolar clamp	2-0201600	1
14	Tibial stylus	2-0202400	1
15	Reamer for tibial extension stem	2-0202700	1
16	Punch for tibial extension stem - size 1/2	2-0202812	1
17	Standard trial stem	2-0208900	3
18	Punch for tibial extension stem - size 3/4/5	2-0202835	1
19	Punch for tibial extension stem - size 6/7	2-0202867	1
20	Headed pin length 30 mm	2-0201301	3
21	Headless pin length 80 mm	2-0201400	3
22	Headed pin length 70 mm	2-0201302	3

# Instrumentation

## Score: Tibial trial set

2-02999130

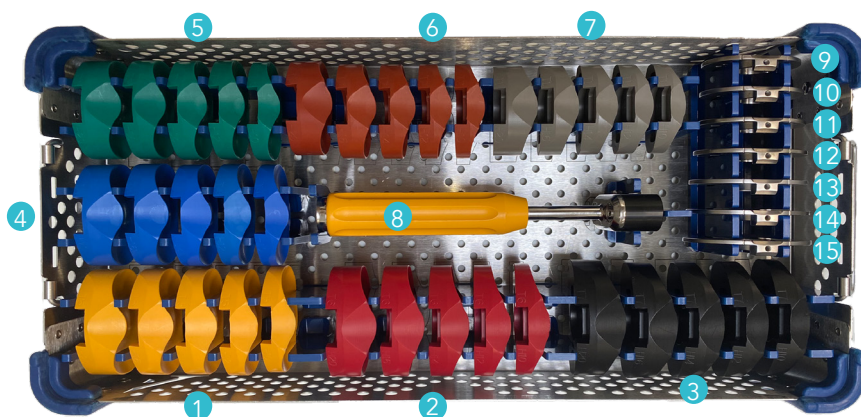

Item	Name	Product No.	Qty
1	Trial Insert Size 1 thickness 10 mm	2-0202911	1
1	Trial Insert Size 1 thickness 12 mm	2-0202921	1
1	Trial Insert Size 1 thickness 14 mm	2-0202931	1
1	Trial Insert Size 1 thickness 16 mm	2-0202941	1
1	Trial Insert Size 1 thickness 20 mm	2-0202951	1
2	Trial Insert Size 2 thickness 10 mm	2-0202912	1
2	Trial Insert Size 2 thickness 12 mm	2-0202922	1
2	Trial Insert Size 2 thickness 14 mm	2-0202932	1
2	Trial Insert Size 2 thickness 16 mm	2-0202942	1
2	Trial Insert Size 2 thickness 20 mm	2-0202952	1
3	Trial Insert Size 3 thickness 10 mm	2-0202923	1
3	Trial Insert Size 3 thickness 12 mm	2-0202923	1
3	Trial Insert Size 3 thickness 14 mm	2-0202933	1
3	Trial Insert Size 3 thickness 16 mm	2-0202943	1
3	Trial Insert Size 3 thickness 20 mm	2-0202953	1
4	Trial Insert Size 4 thickness 10 mm	2-0202914	1
4	Trial Insert Size 4 thickness 12 mm	2-0202924	1
4	Trial Insert Size 4 thickness 14 mm	2-0202934	1
4	Trial Insert Size 4 thickness 16 mm	2-0202944	1
4	Trial Insert Size 4 thickness 20 mm	2-0202954	1
5	Trial Insert Size 5 thickness 10 mm	2-0202915	1
5	Trial Insert Size 5 thickness 12 mm	2-0202925	1
5	Trial Insert Size 5 thickness 14 mm	2-0202935	1
5	Trial Insert Size 5 thickness 16 mm	2-0202945	1
5	Trial Insert Size 5 thickness 20 mm	2-0202955	1



# Instrumentation

## Score: Tibial trial set

2-02999130

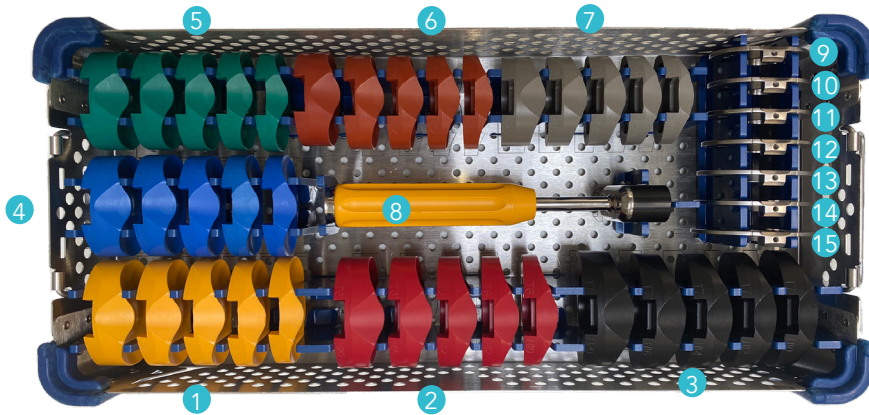

Item	Name	Product No.	Qty
6	Trial Insert Size 6 thickness 10 mm	2-0202916	1
6	Trial Insert Size 6 thickness 12 mm	2-0202926	1
6	Trial Insert Size 6 thickness 14 mm	2-0202936	1
6	Trial Insert Size 6 thickness 16 mm	2-0202946	1
6	Trial Insert Size 6 thickness 20 mm	2-0202956	1
7	Trial Insert Size 7 thickness 10 mm	2-0202917	1
7	Trial Insert Size 7 thickness 12 mm	2-0202927	1
7	Trial Insert Size 7 thickness 14 mm	2-0202937	1
7	Trial Insert Size 7 thickness 16 mm	2-0202947	1
7	Trial Insert Size 7 thickness 20 mm	2-0202957	1
8	Baseplate impactor	2-0203000	1
9	Trial Tibial Baseplate Size 1	2-0208601	1
10	Trial Tibial Baseplate Size 2	2-0208602	1
11	Trial Tibial Baseplate Size 3	2-0208603	1
12	Trial Tibial Baseplate Size 4	2-0208604	1
13	Trial Tibial Baseplate Size 5	2-0208605	1
14	Trial Tibial Baseplate Size 6	2-0208606	1
15	Trial Tibial Baseplate Size 7	2-0208607	1



# Instrumentation

## 4 in 1 with pin positionner (conventional)

2-0299941

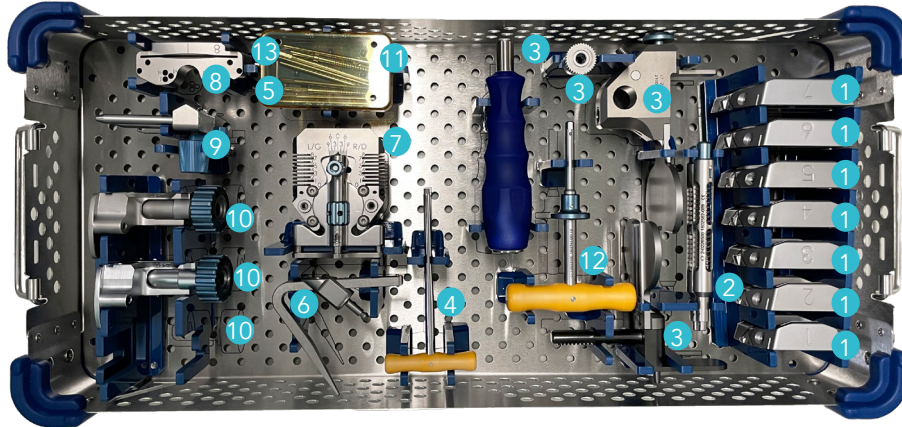

Item	Name	Product No.	Qty
1	4-in-1 Femoral Resection Guide Size 1	2-0226401	1
1	4-in-1 Femoral Resection Guide Size 2	2-0226402	1
1	4-in-1 Femoral Resection Guide Size 3	2-0226403	1
1	4-in-1 Femoral Resection Guide Size 4	2-0226404	1
1	4-in-1 Femoral Resection Guide Size 5	2-0226405	1
1	4-in-1 Femoral Resection Guide Size 6	2-0226406	1
1	4-in-1 Femoral Resection Guide Size 7	2-0226407	1
2	Removable hand holds	2-0226500	2
3	Extra-articular Ligament Balancer V2	2-0233200	1
4	Screwdriver H3.5*	2-0225500	1
5	Headless Pin, Ø3.2 length 65 mm	2-0201402	6
6	4-in-1 Probe	2-0229900	1
7	4-in-1 Pin Positioner	2-0229800	1
8	Distal Resection Guide 8 mm	2-0226900	1
8	Distal Resection Guide 10 mm	2-0228900	1
9	Distal Slide Bar	2-0226800	1
10	Femoral Valgus Alignment Guide 0°	2-0226600	1
10	Femoral Valgus Alignment Guide 3°	2-0226603	1
10	Femoral Valgus Alignment Guide 6°	2-0226606	1
11	H2.5 Wrench	2-0228200	1
12	Snap Screwdriver H5	2-0233100	1
13	Threaded Non-Headed Pin Lg 65mm	2-0255401	2

\* The Screwdriver H3.5 is used in some version of the Femoral Alignment Guide 0°, 3° or 6° to tighten the 2 frontal screws which can locked the Distal Slide Bar.



# Instrumentation

## Score: Femoral trial set

2-02999130

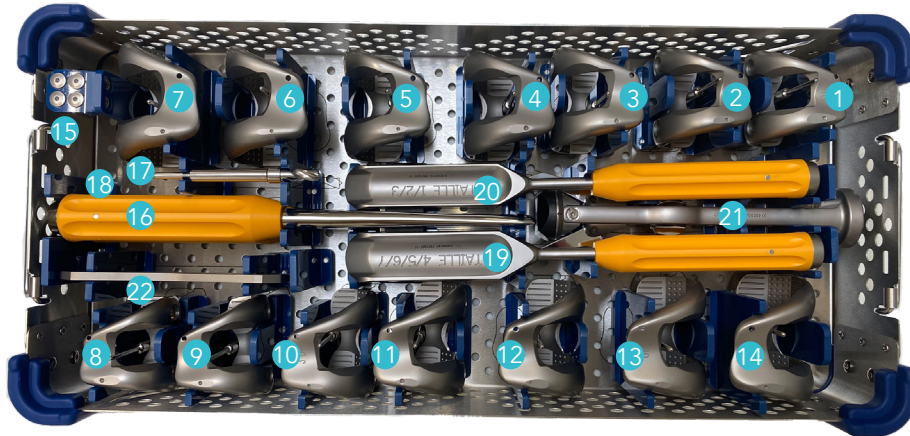

Item	Name	Product No.	Qty
1	SCORE Trial Femoral Component - Right Size 1	2-0208501	1
2	SCORE Trial Femoral Component - Right Size 2	2-0208502	1
3	SCORE Trial Femoral Component - Right Size 3	2-0208503	1
4	SCORE Trial Femoral Component - Right Size 4	2-0208504	1
5	SCORE Trial Femoral Component - Right Size 5	2-0208505	1
6	SCORE Trial Femoral Component - Right Size 6	2-0208506	1
7	SCORE Trial Femoral Component - Right Size 7	2-0208507	1
8	SCORE Trial Femoral Component - Right Size 1	2-0208511	1
9	SCORE Trial Femoral Component - Right Size 2	2-0208512	1
10	SCORE Trial Femoral Component - Right Size 3	2-0208513	1
11	SCORE Trial Femoral Component - Right Size 4	2-0208514	1
12	SCORE Trial Femoral Component - Right Size 5	2-0208515	1
13	SCORE Trial Femoral Component - Right Size 6	2-0208516	1
14	SCORE Trial Femoral Component - Right Size 7	2-0208517	1
15	Trial peg for trial femoral component	2-0206600	4
16	Cutting gauge	2-0206500	1
17	Drill for peg holes	2-0204000	1
18	Femoral component impactor	2-0204300	1
19	Femoral rasp Size 1/2/3	2-0204113	1
20	Femoral rasp Size 4/5/6/7	2-0204147	1
21	Femoral condyle holder	2-0204400	1
22	Intercondylar control gauge	2-0215200	1

# Instrumentation

## SCORE Primary : Patella resection set (conventional)

2-02999132

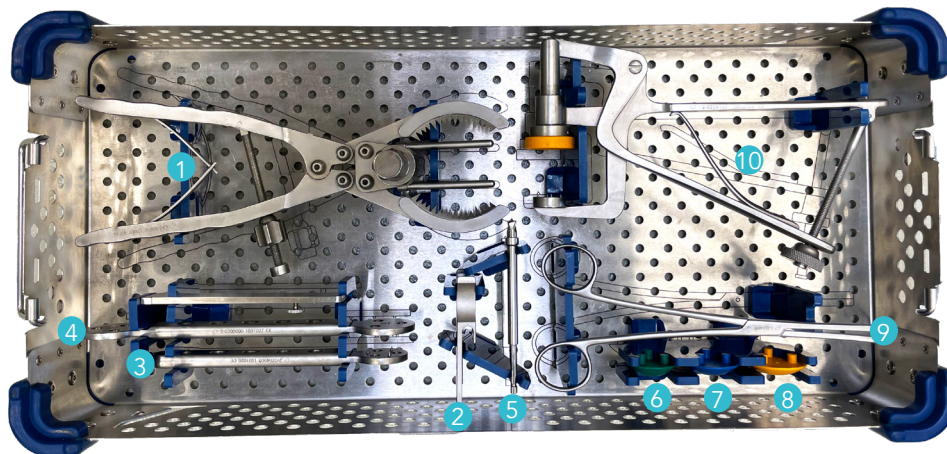

Item	Name	Product No.	Qty
1	Patellar resection Clamp	2-0206700	1
2	Patellar resection gauge	2-0208400	1
3	Patellar Drilling Guide Ø 30	2-0204900	1
4	Patellar Drilling Guide Ø 33 and Ø 36	2-0205000	1
5	Drill bit for resurfacing patella	2-0205100	1
6	Trial resurfacing patella Ø 30	2-0205330	1
7	Trial resurfacing patella Ø 33	2-0205333	1
8	Trial resurfacing patella Ø 36	2-0205336	1
9	Clamp for locking ring	2-0104600	1
10	Patellar Impaction Clamp	2-0206100	1



# Instrumentation

## SCORE Patella set: Patella reaming

2-0299917

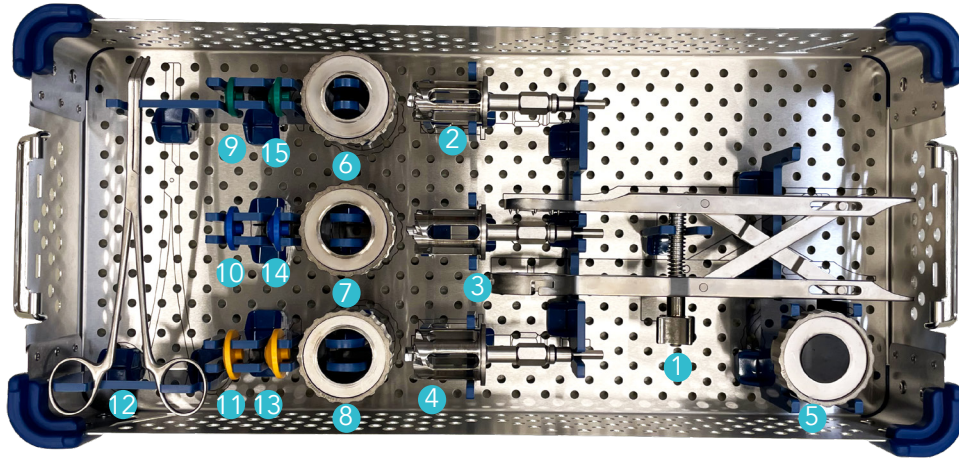

Item	Name	Product No.	Qty
1	Patellar reamer Clamp	2-0216600	1
2	Reamer for inset cementless patella Ø 23	2-0216523	1
3	Reamer for inset cementless patella Ø 26	2-0216526	1
4	Reamer for inset cementless patella Ø 29	2-0216529	1
5	Patellar Reamer Impaction Clamp	2-0216800	1
6	Patella Reamer Surfacing Guides Ø 23	2-0216723	1
7	Patella Reamer Surfacing Guides Ø 26	2-0216726	1
8	Patella Reamer Surfacing Guides Ø 29	2-0216729	1
9	Trial inset patellar - cemented Ø 23—Plastic	2-0205223	1
10	Trial inset patellar - cemented Ø 26—Plastic	2-0205226	1
11	Trial inset patellar - cemented Ø 29—Plastic	2-0205229	1
12	Clamp for Locking ring	2-0104600	1
13	Trial inset patellar - cementless Ø 29 —Plastic	2-0216929	1
14	Trial inset patellar - cementless Ø 26—Plastic	2-0216926	1
15	Trial inset patellar - cementless Ø 23—Plastic	2-0216923	1

# Instrumentation

## Score: Tibial revision

2-0299912

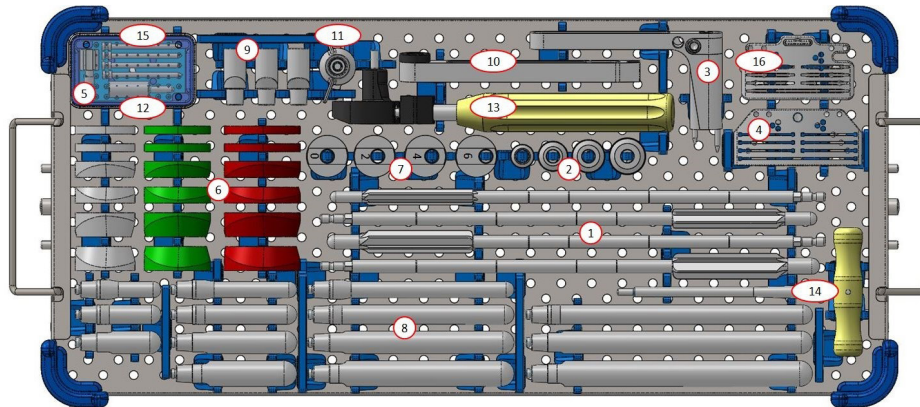

Item	Name	Product No.	Qty
1	Reamer $\varnothing$ 10	2-0210510	1
1	Reamer $\varnothing$ 12	2-0210512	1
1	Reamer $\varnothing$ 14	2-0210514	1
1	Reamer $\varnothing$ 16	2-0210516	1
2	Sleeve 10/15*	2-0211400	1
2	Sleeve 12/19*	2-0211401	1
2	Sleeve 14/21*	2-0211402	1
2	Sleeve 16/23*	2-0211403	1
3	Revision Tibial Bracket	2-0211000	1
4	Revision Tibial Resection Guide	2-0210600	1
5	Wheel for Resection Guide	2-0203800	1
6	Trial Tibial Half-Wedge - Size 1/2 thickness 5 mm	2-0210311	2
6	Trial tibial half-wedge - Size 1/2 thickness 10 mm MED.R / LAT.L	2-0210321	1
6	Trial tibial half-wedge - Size 1/2 thickness 15 mm MED.R / LAT.L	2-0210331	1
6	Trial tibial half-wedge - Size 1/2 thickness 10 mm LAT.R./MED.L	2-0210341	1
6	Trial tibial half-wedge - Size 1/2 thickness 15 mm LAT.R./MED.L	2-0210351	1
6	Trial Tibial Half-Wedge - Size 3/4/5 thickness 5 mm	2-0210313	2
6	Trial tibial half-wedge - Size 3/4/5 thickness 10 mm MED.R / LAT.L	2-0210323	1
6	Trial tibial half-wedge - Size 3/4/5 thickness 15 mm MED.R / LAT.L	2-0210333	1
6	Trial tibial half-wedge - Size 3/4/5 thickness 10 mm LAT.R./MED.L	2-0210343	1
6	Trial tibial half-wedge - Size 3/4/5 thickness 15 mm LAT.R./MED.L	2-0210353	1
6	Trial tibial half-wedge - Size 6/7 thickness 5 mm	2-0210316	2
6	Trial tibial half-wedge - Size 6/7 thickness 10 mm MED.R / LAT.L	2-0210326	1
6	Trial tibial half-wedge - Size 6/7 thickness 15 mm MED.R / LAT.L	2-0210336	1
6	Trial tibial half-wedge - Size 6/7 thickness 10 mm LAT.R./MED.L	2-0210346	1
6	Trial tibial half-wedge - Size 6/7 thickness 15 mm LAT.R./MED.L	2-0210356	1

\*Used for Revision TKA

# Instrumentation

## Score: Tibial revision

2-0299912

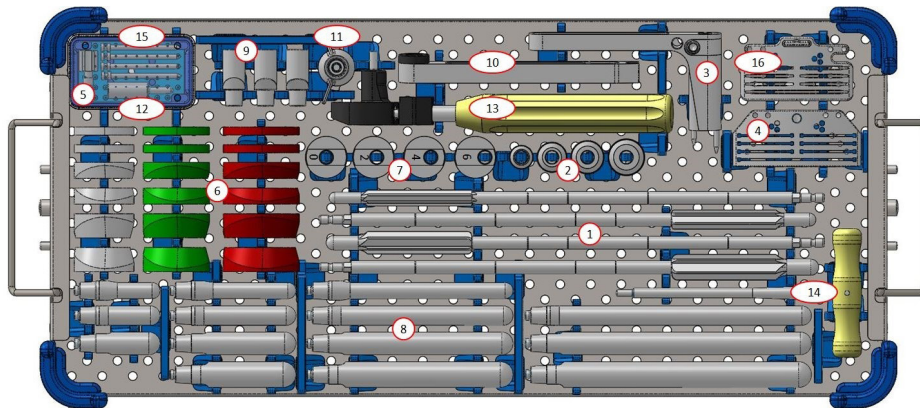

Item	Name	Product No.	Qty
7	Offset Positioner for Trial Tibial Baseplate - 0 mm	2-0213300	1
7	Offset Positioner for Trial Tibial Baseplate - 2 mm	2-0213302	1
7	Offset Positioner for Trial Tibial Baseplate - 4 mm	2-0213304	1
7	Offset Positioner for Trial Tibial Baseplate - 6 mm	2-0213306	1
8	Trial extension stem Ø 12 length 75 mm	2-0209021	1
8	Trial extension stem Ø 12 length 75 mm	2-0209022	1
8	Trial extension stem Ø 14 length 75 mm	2-0209023	1
8	Trial extension stem Ø 10 length 100 mm	2-0209013	1
8	Trial extension stem Ø 12 length 100 mm	2-0209001	1
8	Trial extension stem Ø 14 length 100 mm	2-0209004	1
8	Trial extension stem Ø 16 length 100 mm	2-0209007	1
8	Trial extension stem Ø 10 length 150 mm	2-0209014	1
8	Trial extension stem Ø 12 length 150 mm	2-0209002	1
8	Trial extension stem Ø 14 length 150 mm	2-0209005	1
8	Trial extension stem Ø 16 length 150 mm	2-0209008	1
8	Trial extension stem Ø 12 length 200 mm	2-0209003	1
8	Trial extension stem Ø 14 length 200 mm	2-0209006	1
8	Trial extension stem Ø 16 length 200 mm	2-0209009	1
9	Trial Offset Connector 2 mm	2-0214102	1
9	Trial Offset Connector 4 mm	2-0214104	1
9	Trial Offset Connector 6 mm	2-0214106	1
10	Wrench for Offset Connector	2-0213500	1
11	Delta Wing for Tibial Trials	2-0213401	1
12	Thumb Knob to Connect Baseplate / Delta Wing	2-0215400	1
13	Tibial Impactor with Offset Connector	2-0213700	1
14	Extractor for Offset Connector	2-0214300	1
15	Headed Pin length 50 mm	2-0201303	4
16	4T Tibial Resection Guide - Revision	2-0253300	1

# Instrumentation

## Large saw blades

**Synthes AO / SODEM large sawblade**

Sterile product No. 2-0227901

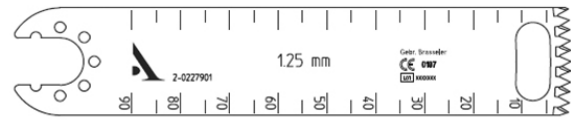

**STRYKER large sawblade**

Sterile product No. 2-0227902

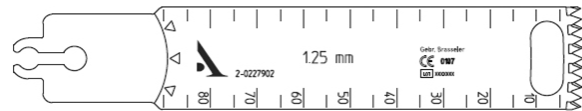

**ZIMMER / HALL / LINVATEC large sawblade**

Sterile product No. 2-0227903

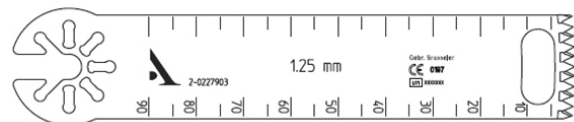

## Medium saw blades

**Synthes AO / SODEM medium sawblade**

Sterile product No. 2-0228001

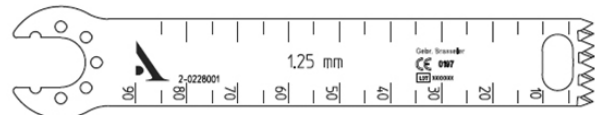

**STRYKER medium sawblade**

Sterile product No. 2-0228002

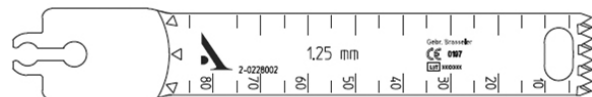

**ZIMMER / HALL / LINVATEC medium sawblade**

Sterile product No. 2-0228003



Not all devices presented in this Surgical Technique may be distributed in your country. Please contact your Amplitude Sales Representative for availability.



# Appendix A

## Assembly and disassembly of the ligament balancer V2

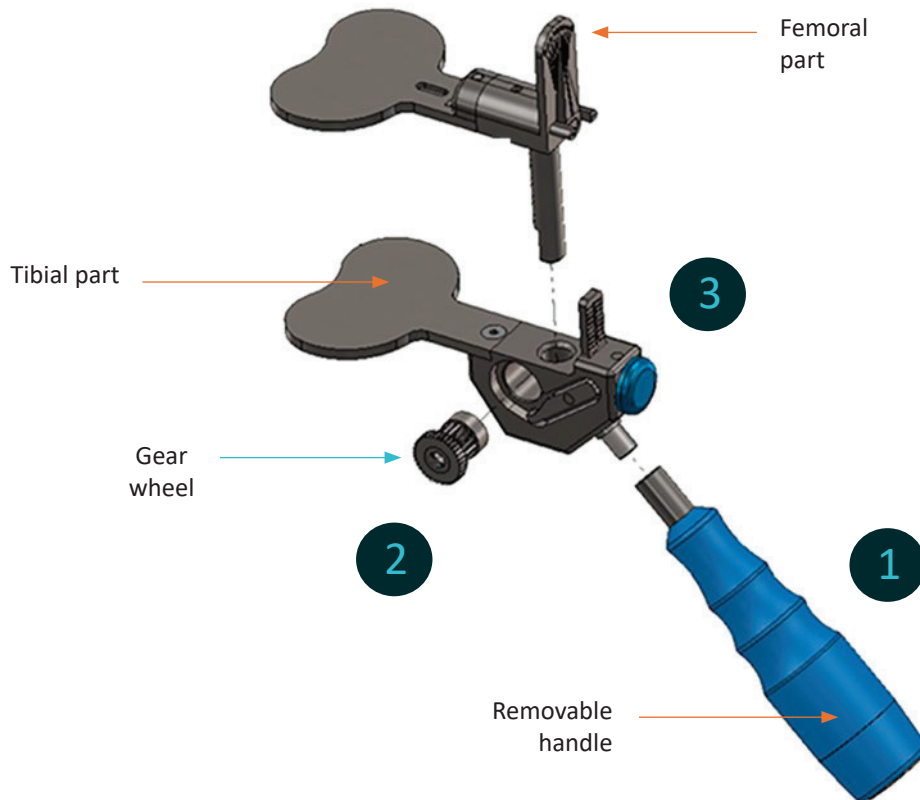

### Assembly of balancer:

- 1 Screw the removable handle onto the tibial housing.
- 2 Place the gear wheel into the lateral opening on the tibial housing.
- 3 Press the blue button and insert the femoral housing on top of the tibial housing.

### Dissassembly of balancer:

Repeat the above steps in the reverse order.

---

# Appendix B

## Assembly and disassembly of the 4-in1 pin positioner

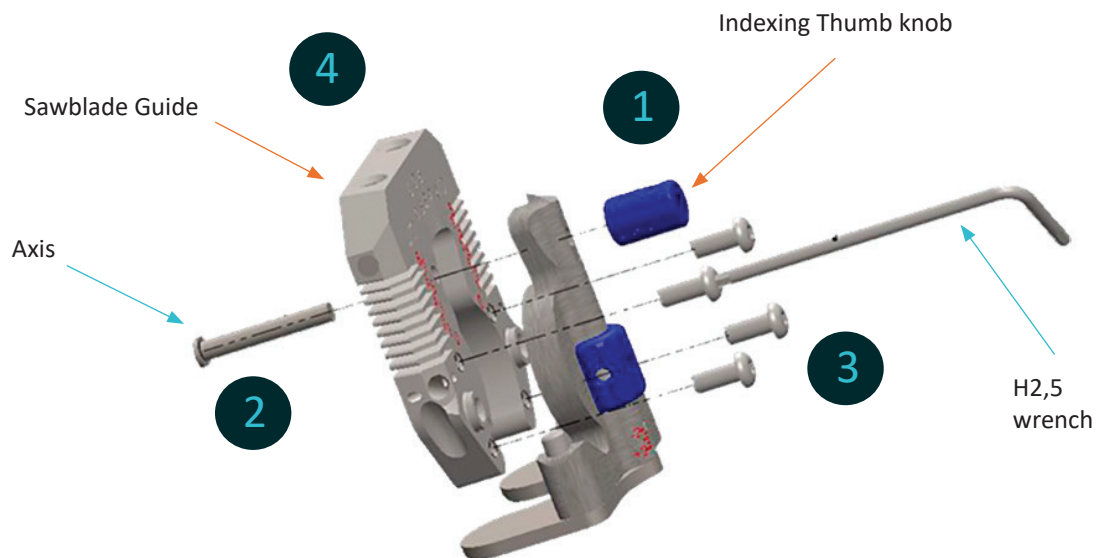

### Disassembly of Pin Positioner:

- 1 Unscrew the indexing thumb knob.
- 2 Remove the dowel.
- 3 Unscrew the pan-head screw with the H2.5 wrench.
- 4 Remove the saw blade guide.

### Assembly of Pin Positioner:

Repeat the above steps in the reverse order.

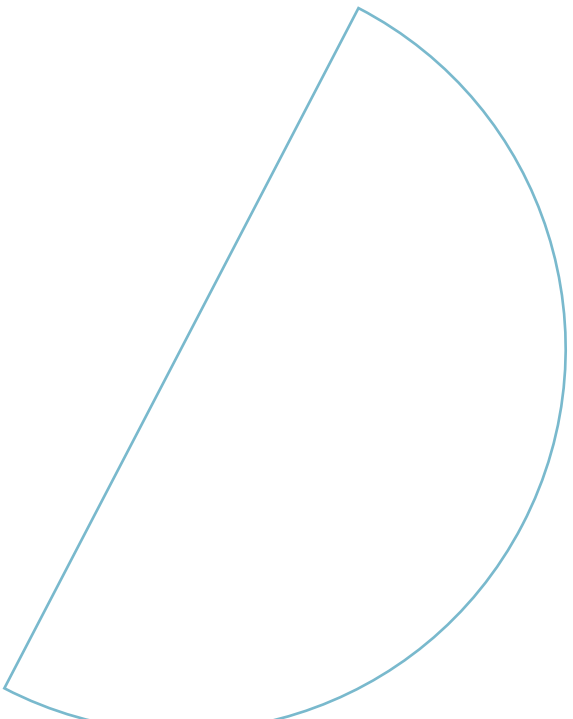



**Customer Service – France:**

Porte du Grand Lyon,  
01700 Neyron – France  
Phone: **+33 (0)4 37 85 19 19**  
Fax: +33 (0)4 37 85 19 18  
E-mail: [amplitude@amplitude-ortho.com](mailto:amplitude@amplitude-ortho.com)

**Customer Service – Export:**

11, cours Jacques Offenbach,  
ZA Mozart 2,  
26000 Valence – France  
Phone: **+33 (0)4 75 41 87 41**  
Fax: +33 (0)4 75 41 87 42

[www.amplitude-ortho.com](http://www.amplitude-ortho.com)